

IRON BALTIC

VAUHTI VARIKKO

MULTILINGUAL MANUAL



<https://code.ironbaltic.com/u/UVbuMv0y>

CLUTCH KIT STAGE 3 BIG TIRE & MUD SEGWAY SNARLER AT10 Code 80.10400

Version Rev01 (12122025)



Distributor **IronBaltic, Estonia**

Producer **Vauhti Varikko, Finland**

Keep this manual for future reference!

If you need any spare parts, please send this packaging data to your local dealer or to Iron Baltic sales@ironbaltic.com

Iron Baltic Ltd | +372 653 3711 | sales@ironbaltic.com | www.ironbaltic.com

SPECIFICATION

Pos.	Description	Code	Amount
1	Primary spring (GREEN-BLACK marked)	80.10301	1
2	Weight (BLUE marked)	80.202	6
3	Washer 1 mm	80.102	1
4	Helix 40°- 48°	80.1151	1
5	Secondary clutch spring	80.1001	1
6	Bolt M6x60 DIN933	OT.02.02.140	1
7	Sticker (VauhtiVarikko)	PM.13.05.024	1
8	Sticker (IronBaltic)	PM.13.05.007	1



All pictures in this manual are for illustration purposes only and may differ from real product due to the changes made to the product during improvements!

INSTRUCTIONS

Thank You that you have chosen our clutch kit. Our clutch kit helps to transfer the engine power better to the wheels so you can use the engine potential more effectively and vehicle is smoother to use. We have gone through long testing period – including real life driving tests as well as the dynamometer tests - before we have chosen this specific setup combination.

Clutch upgrade kits are fully tested and accepted by most SEGWAY distributors. Correctly installed upgrade kit will not cause any damages to your vehicle. The manufacturer of the clutch kit is not responsible for any damage or failure of your vehicle or in case the warranty of your machine will be voided. To ensure correct installation and to avoid possible inconveniences we recommend ordering the installation from an authorized SEGWAY dealer.

Stage 3 Mud Kit (Tires 30"-32")

- Big tire kit for Mud use! Helps to transfer the engine power better to the wheels!
- Smoother engagement!
- The lower part of Helix will let you drive at low speed with higher rpm and therefore gives you more HP and Torque to the wheels. This will give you a lot of tire-turning torque to hammer through thick mud.
- The higher part of the helix is designed to give more and more upshifting with same rate as your engine is making more power!
- Quicker backshift which results in crisp throttle response!
- Reduces belt slip and heat.
- This is the kit for you if you love riding in thick mud or have big tires!

We recommend using official dealership installation services; they have the correct tools and knowledge for such installation.

Clutch kit is designed for SEGWAY original belts, when using aftermarket belts make sure that its same width than original. Wider belts may need one extra washer to have right engage rpm. Washer is sold separately (P/N 80.102)

- 1 – Clutch bolt
- 2 – Cover plate nut
- 3 – Primary clutch
- 4 – Weight slider
- 5 – Weight
- 6 – Clutch spring
- 7 – Secondary clutch
- 8 – Sliding flange
- 9 – Secondary clutch spring
- 10 – Key
- 11 – Helix
- 12 – Retaining ring

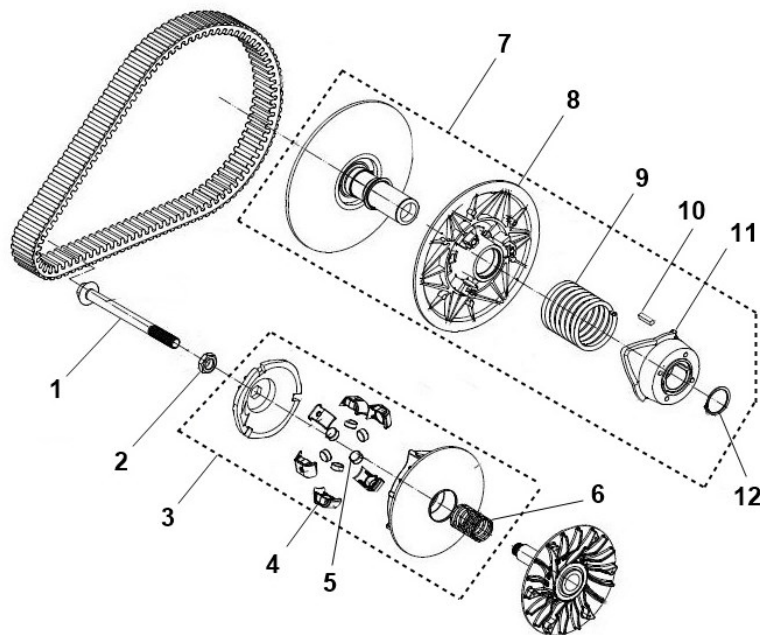

1. Remove left side rear footrest and side plastic.

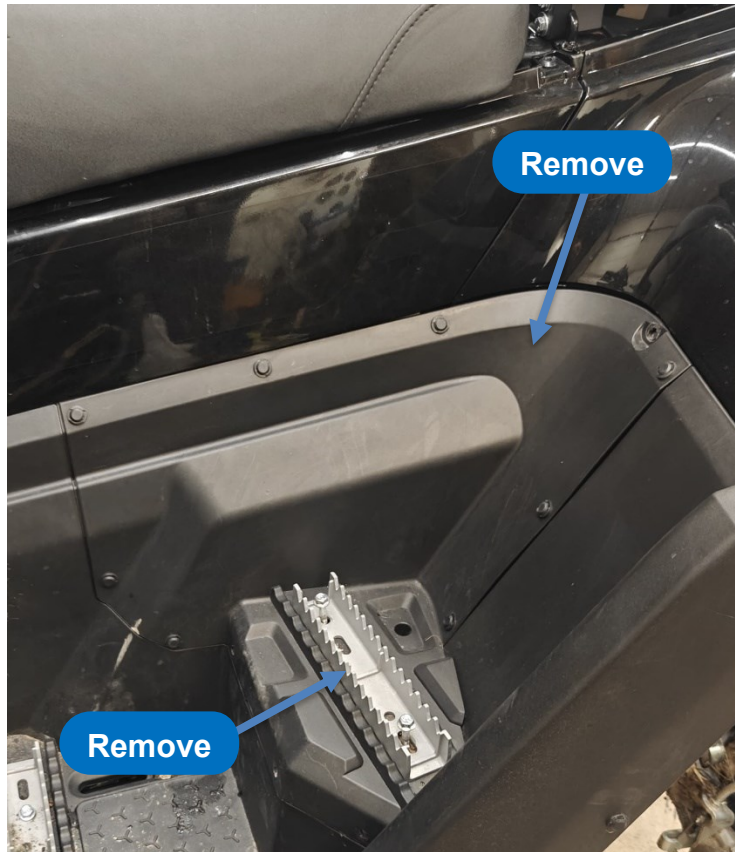

2. Remove the crossbar from the left side.



3. Open CVT cover.



4. Install the clutch holding tool (80.1700).

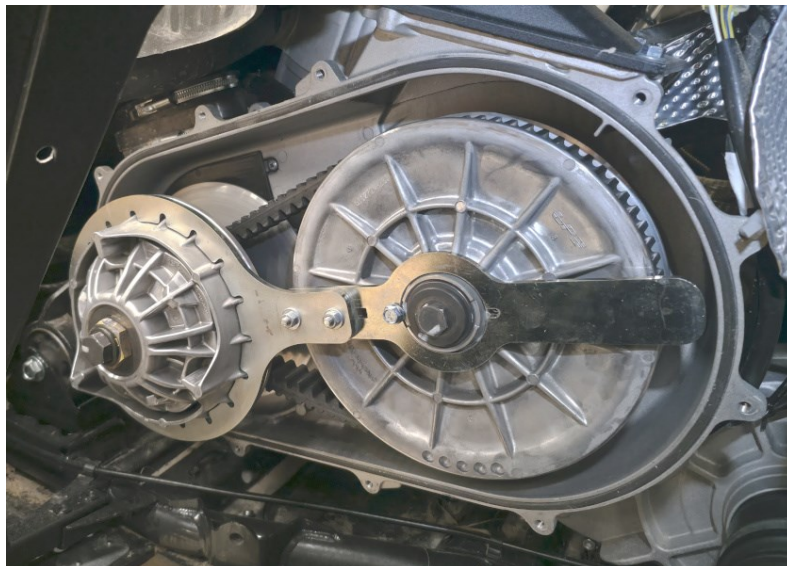

5. Remove the secondary clutch bolt.



6. Remove the primary clutch bolt. **NB! Bolt has left hand thread!**



7. Remove the primary clutch cover plate nut. **NB! Nut has left hand thread!**



8. Remove primary clutch and original clutch spring.



9. Remove the weight sliders from the primary clutch.
NB! Mark the position of cover plate and primary before disassembling!



10. Remove original weights and replace them with new weights (Pos.2).

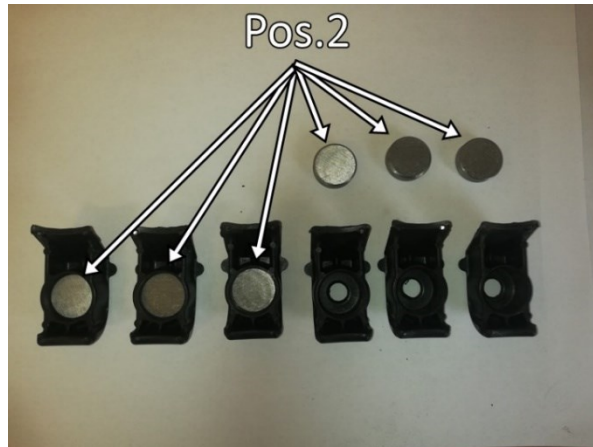

11. Reassemble the primary clutch. NB! Notice the marks you made in Step.9!



12. Loosen variator belt by screwing M6 (Pos.6) bolt into the secondary clutch, at the locations shown in the picture, to separate the secondary clutch sides, making the removal easier. Remove the secondary clutch. After clutch removal, remove the M6 bolt.



13. Open secondary clutch.
A special tool (clutch spring compression tool: 80.400) is required.

a. Place the secondary clutch to tool



b. Lower the helix with the compression tool until the retaining ring appears.



c. Remove the retaining ring. Use an appropriate pair of pliers.



- d. Raise the compression tool slowly until the spring pressure is completely loosened and you can remove the helix. Be careful of the loaded spring!



14. Install new helix (Pos.4).

There are holes in the helix and sliding flange for position the spring.

In the helix, the holes are marked with numbers (1,2,3,4) and in the sliding flange, the holes are marked with letters (A, B, C).



15. Set the new secondary clutch spring (Pos.5) to position **B-1** with new multiangle helix!



16. Reassemble the secondary clutch.

a. Press the helix with compression tool.



b. Align the keyways and insert the key.



- e. Turn the helix counterclockwise to pre-stress the spring to the installation position. Make sure that the helix goes to the right side of the cam shoes!

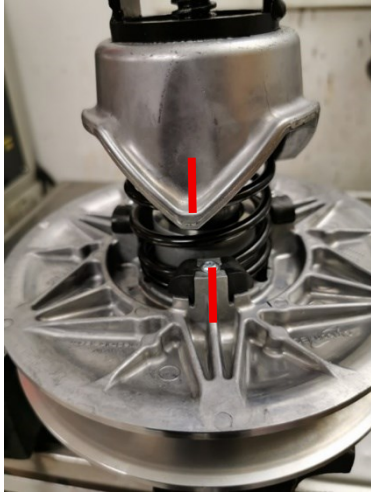

Spring zero position.
Wrong position!

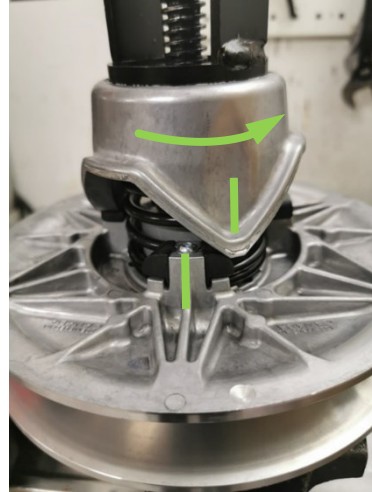

Spring pre-stressed
position / Correct
installation position

- c. Press the helix with compression tool until you can install the retaining ring back.



- f. Remove the compression tool.

17. Re-install the secondary clutch and variator belt. For easier installation, screw in the M6 bolt to secondary clutch (see Step 12).



18. Install washer (Pos.3) under clutch spring (engine side).



19. Install new spring (Pos.1).

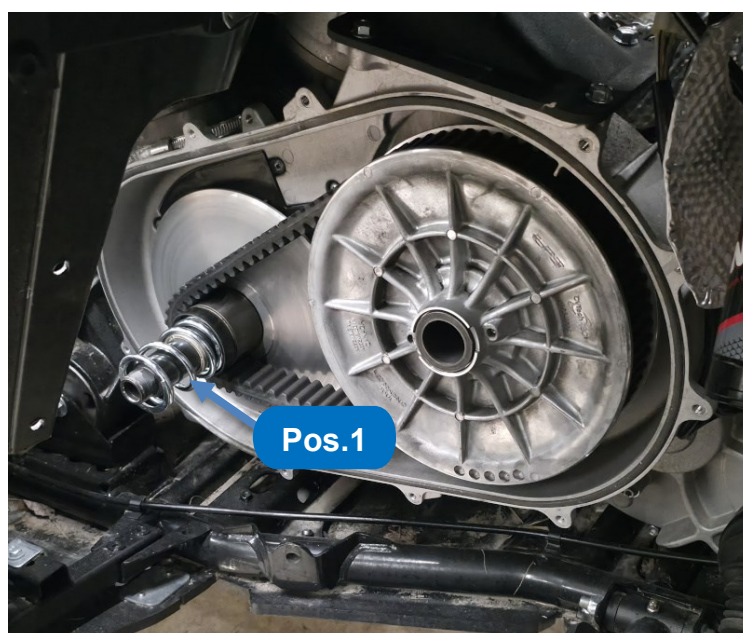

20. Re-install the primary clutch in place.



21. Reinstall the back plate nut. Do not tighten it. Use thread-lock glue. **NB! Nut has left hand thread!**

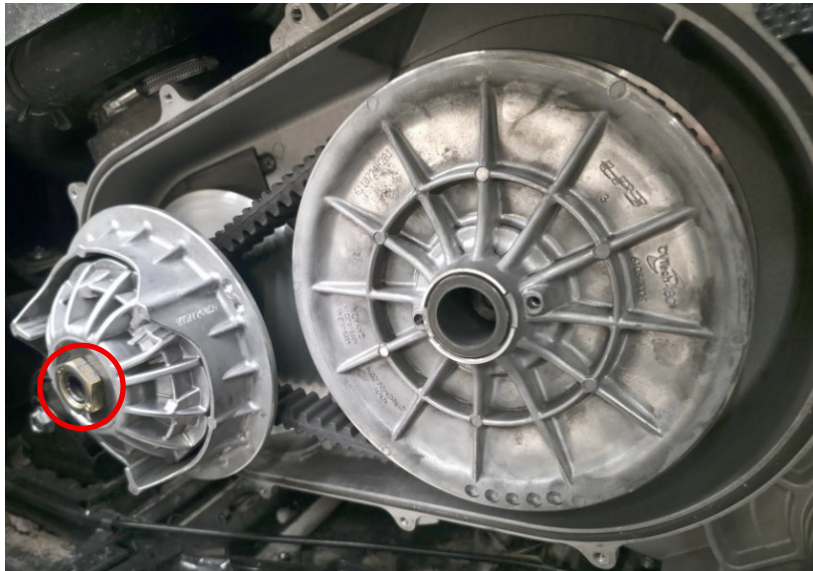

22. Reinstall the Clutch Bolt. Do not tighten it. Use thread-lock glue. **NB! Bolt has left hand thread!**

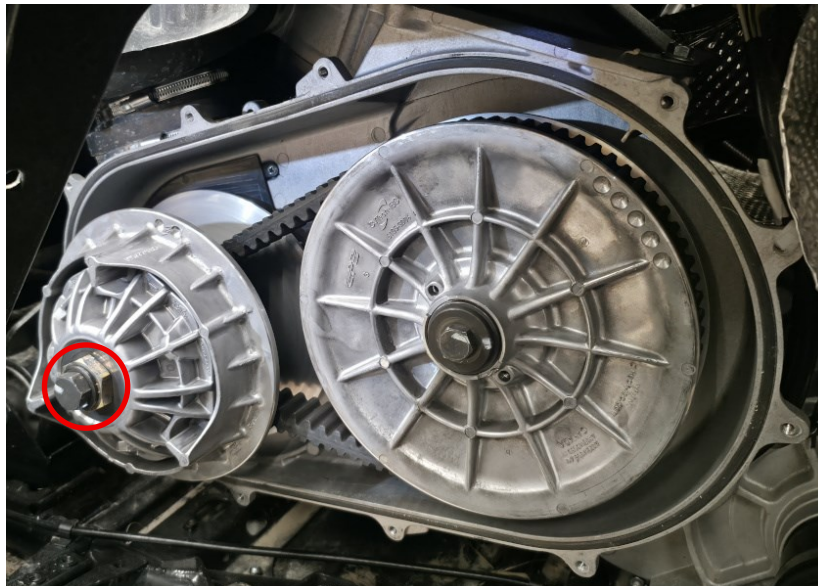

23. Reinstall secondary clutch bolt. Do not tighten it. Use thread-lock glue.

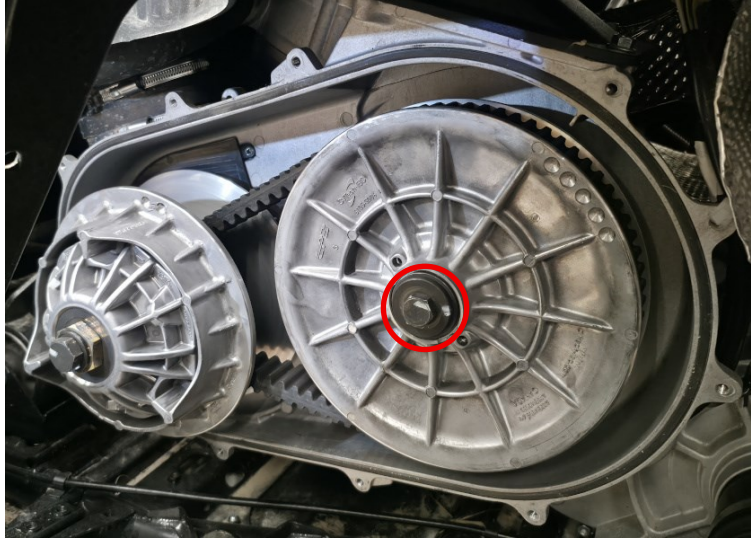

24. Install the clutch holding tool (80.1700)

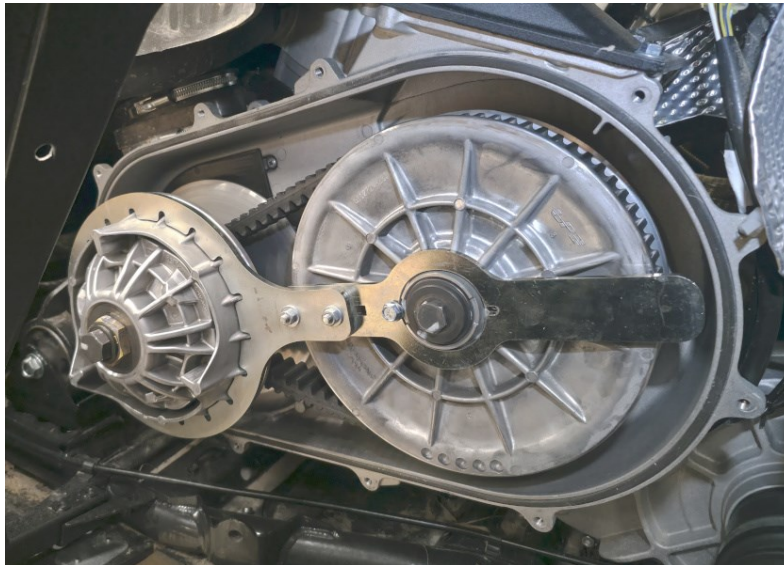

25. Tighten clutch bolts / nuts.

- a. Tighten **back plate nut** to 105 Nm. **NB! Nut has left hand thread!**
- b. Tighten the **clutch bolt** to 120 Nm. **NB! Nut has left hand thread!**
- c. Tighten the **secondary clutch bolt** to 80 Nm

26. Remove clutch holding tool

27. Check that everything is secured and install CVT cover back (tighten to 12Nm)

28. Install the crossbar

29. Install left side plastic

You are ready to test drive!

IRON BALTIC

IRON BALTIC OÜ
Joa tee 17
Vääna 76903
Estonia / Europe

+372 6 533 711
sales@ironbaltic.com

www.ironbaltic.com
www.facebook.com/ironbaltic
www.youtube.com/user/ironbalticLtd