

# IRON BALTIC

## STUMP GRINDER SG-8

DOWNLOAD MULTILINGUAL  
USER MANUAL

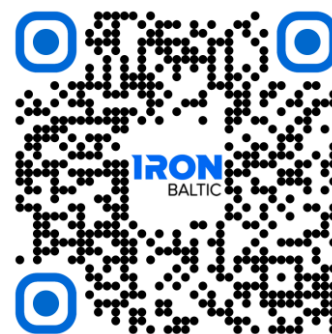

[code.ironbaltic.com/u/nQLiCVCC](https://code.ironbaltic.com/u/nQLiCVCC)

Code 95.1000

Version 21082024



**Keep this manual for future reference!**

If you need any spare parts, please send this packaging data to your local dealer or to Iron Baltic  
[sales@ironbaltic.com](mailto:sales@ironbaltic.com)



# CONTENTS

|   |    |
|---|----|
| EC DECLARATION OF CONFORMITY .....                    | 5  |
| INTRODUCTION .....                                    | 6  |
| GENERAL .....   | 7  |
| ENGINE MANUAL.....                                    | 7  |
| EMISSION CONTROL SYSTEM.....                          | 7  |
| ENVIRONMENTAL.....                                    | 7  |
| MODEL AND SERIAL NUMBERS.....                         | 7  |
| DISCLAIMER .....                                      | 7  |
| INSPECT COMPONENTS .....                              | 7  |
| WARNING.....  | 8  |
| UNDERSTAND YOUR MACHINE .....                         | 9  |
| PERSONAL SAFETY .....                                 | 9  |
| PERSONAL PROTECTIVE EQUIPMENT (PPE) REQUIREMENTS..... | 9  |
| NOISE AND VIBRATION LEVELS .....                      | 9  |
| INSPECT YOUR MACHINE .....                            | 10 |
| ENGINE SAFETY.....                                    | 10 |
| FUEL SAFETY .....                                     | 10 |
| STATIC ELECTRICITY AND FILLING GASOLINE.....          | 11 |
| HAZARDS DURING FUELING.....                           | 11 |
| PRIOR TO STARTING .....                               | 12 |
| OPERATION SAFETY .....                                | 12 |
| MACHINE USE .....                                     | 13 |
| PROHIBITION AGAINST MODIFICATIONS.....                | 13 |
| INSPECTION / MAINTENANCE.....                         | 14 |
| ABOUT YOUR GRINDER .....                              | 14 |
| SAFETY LABELS .....                                   | 15 |
| PRODUCT DESCRIPTION .....                             | 16 |
| OPERATION .....                                       | 17 |
| CHECK/ADD OIL TO ENGINE .....                         | 17 |
| CHECK/ADD GASOLINE TO ENGINE.....                     | 17 |
| REFUELING.....  | 18 |
| INSPECT FUEL SYSTEM/CHECK FOR LEAKS .....             | 19 |
| CHECK CONTROLS .....                                  | 19 |
| INSPECT CUTTING TEETH .....                           | 19 |
| WORK DURING DAYLIGHT .....                            | 19 |
| CLEAR AREA.....                                       | 19 |
| TRIM STUMP WITH SAW .....                             | 19 |
| LOCKING HANDLE BAR.....                               | 20 |
| STARTING THE GRINDER.....                             | 20 |
| STOPPING THE GRINDER .....                            | 21 |
| GRINDING THE STUMP .....                              | 21 |
| IDLE SPEED .....                                      | 22 |

|   |    |
|---|----|
| TRANSPORTING .....                          | 22 |
| KNOW YOUR MACHINE .....                     | 23 |
| SPECIFICATION .....                         | 24 |
| ASSEMBLING GUIDE .....                      | 25 |
| MAINTENANCE .....                           | 32 |
| PREVENTIVE MAINTENANCE .....                | 32 |
| REGULAR MAINTENANCE CHECKLIST .....         | 32 |
| PERFORM ENGINE MAINTENANCE .....            | 33 |
| INSPECT FUEL SYSTEM / CHECK FOR LEAKS ..... | 33 |
| GREASE .....                                | 33 |
| TEETH WEAR.....                             | 33 |
| CHECK AND ADJUST BRAKE.....                 | 33 |
| STOP-SWITCH ADJUSTMENT.....                 | 34 |
| STORAGE .....                               | 35 |
| START GRINDER EVERY 4 WEEKS.....            | 35 |
| TROUBLESHOOTING .....                       | 36 |
| SPARE PARTS REPLACEMENT .....               | 37 |
| BELTS REPLACEMENT .....                     | 37 |
| CLUTCH REPLACEMENT .....                    | 39 |
| TEETH AND HOLDER REPLACEMENT .....          | 42 |

## EC DECLARATION OF CONFORMITY

Manufactured by: Weifang Austter Industry and Trade Co., Ltd.  
Address: East Mountain Industrial Park, Shuangfeng Avenue, Xing'an Street, AnQiu,  
Weifang City, Shandong Province 262100, P. R. China

Agent: Iron Baltic OÜ  
Address: Põldmäe tee 1, Vatsla 76915, Estonia

Product: Code: **95.1000**  
Type: **Stump Grinder**  
Type: **SG-8**

We certify that the product complies with the requirements of Directive **2006/42/EC** relating to the safety and functionality of the machinery, Directive **2000/14/EC** relating to the noise emission in the environment and is in compliance with the requirements of applicable standards: **EN ISO 12100:2010; EN 13525:2020; EN ISO 14982:2009.**

In witness whereof CE marking is attached to the product.

Notified body: TÜV Rheinland/CCIC (Qingdao) Co., Ltd.  
Address: 6F, No.2 Bldg., No.175 Zhuzhou Road, Qingdao 266101, P.R. China

Measured sound power level: **103.8 dB**  
Applicable conformity assessment procedure: **EN ISO 4871:2009.**

Place and date of issue of the declaration: 21.08.2024



# INTRODUCTION

Thank you for choosing this product. This manual provides instructions on the safe operation and maintenance of the stump grinder. This machine is designed solely to grind tree stumps and must not be used for any other purpose. The non-intended use of the stump grinder may cause economic loss and cause injuries; hence it is very important that the person who uses the product, reads this manual carefully and uses the product accordingly. It is potentially hazardous to fit or use any parts other than your dealer parts. Any misuse of the product releases the manufacturer from the responsibility for occurred damage and compensation of costs.

**NOTE:** We reserve the right to discontinue, change, and improve products at any time without notice or obligation to the purchaser. The descriptions and specifications contained in this manual were in effect at printing. Equipment described within this manual may be optional. Some illustrations may not be applicable to your machine.



**This symbol is used throughout the manual and on warning signs in order to warn users of the potential for serious injury. Before using the stump grinder, carefully read the safety instructions and make sure that you have understood them. Follow all instructions and ensure that everyone who uses the equipment follows them!**

**Keep this manual for future reference.**

**Based on the specifications for your model, please check that you have received all of the parts for your particular set.**

# GENERAL

This unit is a stump grinder powered by a gasoline engine. It is designed to grind stumps into chips. It offers quality solid steel construction and is easy and safe to operate. With proper use and care, it should give you many years of dependable service.

Your stump grinder is intended for outdoor-use only and can be used to remove tree stumps and exposed root systems close to ground level. By moving the blade in sweeping movements laterally over the top and front of the stump, you can gradually grind it away.

- Read this Owner's Manual and the engine Owner's Manual completely before attempting to use and service the grinder. Serious injury or death can result if safety instructions are not followed.
- The grinder owner or rental company must instruct all operators in the safe setup and operation of the grinder. Do not allow anyone to operate the grinder who has not read the Owner's Manual and received instruction on its safe use. Ensure that Owner's Manual is stored in attached storage tube on the grinder.
- Only trained adults should operate and service the grinder. Do not let children operate.
- Never operate the grinder, or allow anyone else to operate it, while under the influence of alcohol, drugs or medication.
- Carefully read and understand the intended use of this grinder. Do not use it for other purposes, as this may result in unforeseen hazards or equipment damage.
- Learn how to use the machine and its controls safely. Understand and follow all safety labels.
- Avoid using the grinder in poor or uncertain weather conditions that in slippery ground.

## ENGINE MANUAL

The **Engine Manufacturer** is responsible for all engine-related issues with regards to performance, power rating, specifications, warranty and service. Please refer to the **Engine Manufacturer's** owner/operator's manual, packed separately with your unit, for more information.

## EMISSION CONTROL SYSTEM

This equipment and or its engine may include exhaust and evaporative emission control system components required to meet U.S. Environmental Protection Agency (EPA) and/or California Air Resources Board (CARB) regulations. Tampering with emission controls and components by unauthorized personnel may result in severe fines or penalties. Emission controls and components can only be adjusted by an authorized engine manufacturer's service center.

## ENVIRONMENTAL



**Recycle unwanted materials instead of disposing of them as waste. All tools, hoses and packaging should be re-sorted, taken to the local recycling center and disposed of in an environmentally safe way.**

## MODEL AND SERIAL NUMBERS

Record the model and serial number as well as date and place of purchase for future reference. Keep this information available when ordering parts or optional accessories and for any technical or warranty inquiries.

## DISCLAIMER

Stump grinder manufacturer reserves the right to discontinue, change, and improve its products at any time without notice or obligation to the purchaser. The descriptions and specifications contained in this manual were in effect at printing. Equipment described within this manual may be optional. Some illustration may not be applicable to your unit.

## INSPECT COMPONENTS

Closely inspect to make sure no components are missing or damaged. See the "ASSEMBLING GUIDE" section for instructions on whom to contact to report missing or damaged parts.

# SAFETY INSTRUCTIONS

This manual provides an overview of essential safety procedures and measures. Keep this summary handy and refer to it regularly to ensure you understand and follow the proper safety protocols for using your stump grinder.

Most accidents occur due to negligence or carelessness. Avoid unnecessary accidents and follow the safety instructions given below.

List of warnings and cautions cannot be all-inclusive. If situations occur that are not covered by this manual, the operator must apply common sense and operate this stump grinder in a safe manner. Contact dealer for assistance in your area.

Identify hazards and take preventive steps to avoid accidents and minimize risk. Possible hazards include, but are not limited to, moving parts, thrown objects, weight of the machine and components, and the operating environment.

## WARNING

Carefully read and understand the following safety information before using the grinder. Improper use or maintenance can result in serious injury or death due to fire/explosion, carbon monoxide poisoning, lacerations, entanglement or burns. Damage can also occur to windows, siding, vehicles, and bystanders from chips and debris which can become projectiles.



**READ AND UNDERSTAND THIS MANUAL COMPLETELY BEFORE USING THE GRINDER!**

- Failure to properly operate and maintain this grinder could result in serious injury or death to the operator or bystanders.
- All machines have hazards associated with their operation. This stump grinder has certain special hazards, which you must be aware of. As an operator or owner, it is your responsibility to understand these hazards.
- When reading this manual pay particular attention to avoiding these hazards.

In particular, be aware of the following:

- Know location of buried electrical and other utility lines.
- Do not allow children or untrained adults to operate.
- Wear eye protection and other personal protection against flying rocks and debris.
- Check that cutter wheel teeth are secured, sharp and not missing.
- Make sure no children or bystanders are within 25 m (75 ft) of stump grinding operation
- Protect cars, windows and other objects within 25 m (75 ft) from flying debris.
- Be prepared for machine "kickback" when initially contacting the stump.
- Be aware of potential carbon monoxide (CO) poisoning.
- Take precautions to prevent fires and explosions during fueling.
- Do not attempt to perform adjustments or clean the unit while the engine is running.
- Take care to prevent burns from the engine or hot exhaust.
- Avoid operating in wet or icy conditions with a high risk of falling.

## UNDERSTAND YOUR MACHINE

- Read this manual and labels affixed to the machine to understand its limitations and potential hazards.
- Be thoroughly familiar with the controls and with the proper use of the equipment. Know how to stop the machine and disengage the controls quickly.
- Make sure to read and understand all the instructions and safety precautions as outlined in the Engine Manufacturer's manual packed separately with your unit.
- Do not attempt to operate the machine until you fully understand how to properly operate and maintain the engine and how to avoid accidental injuries and/or property damage.
- If the unit is to be used by someone other than original purchaser or loaned, rented, or sold, always provide this manual and any needed safety training before operation. The user can prevent and is responsible for accidents or injuries that may occur to themselves, other people, and property.
- Do not force the machine. Use the correct machine for your application. The correct machine will do the job more efficiently and safer at the rate it was designed.

## PERSONAL SAFETY

- Do not permit children to operate this machine at any time.
- Keep children, pets, and other people not using the unit away from the work area.
- Be alert and shutoff unit if anyone enters work area. Keep children under the watchful care of a responsible adult.
- Do not operate the machine while under the influence of drugs, alcohol, or any medication that could affect your ability to use it properly.
- Do not touch parts that might be hot from operation. Allow parts to cool before attempting to maintain, adjust, or service.
- Always keep hands and feet away from all moving parts during operation. Moving parts can cut or crush body parts.
- Stay alert, watch what you are doing, and use common sense when operating the machine.
- Do not overreach. Do not operate the machine while barefoot or when wearing sandals or similar lightweight footwear.
- Always keep proper footing and balance. This enables better control of the machine in unexpected situations.
- Secure longhair so it is above shoulder level. Keep your hair away from moving parts.
- Loose or dangling apparel, jewelry or hair can become entangled in moving parts. Never wear jewellery or loose-fitting clothing when operating the grinder.

## PERSONAL PROTECTIVE EQUIPMENT (PPE) REQUIREMENTS

- Head protection- operators must wear helmet that protects the head from impacts and shields the face from flying debris.
- Eye protection- operators must ensure that the helmet visor provides adequate protection. Bystanders outside or near the danger zone must wear safety goggles or a full-face shield.
- Hearing protection- operators and bystanders must wear hearing protection to protect against harmful noise levels.
- Hand protection- operators must wear heavy-duty work gloves which protects hands from cuts, abrasions, and vibrations while ensuring a secure grip on controls.
- Foot protection- operators must wear steel-toe or reinforced boots with anti-slip soles. These boots shield feet from heavy objects, sharp debris, and potential impacts, while the anti-slip soles help prevent slipping on wet or uneven surfaces.
- Body protection- operators must wear long-sleeved protective clothing and a high-visibility vest. This clothing protects the body from debris and enhances visibility in various working conditions. It should be durable and resistant to cuts and abrasions.

## NOISE AND VIBRATION LEVELS

- A-weighted sound power level emitted by the machine: 103.8dB
- A-weighted emission sound pressure level at the operator's station: 90.8dB
- The vibration total value to which the hand-arm system is subjected, less than 6.9 m/s<sup>2</sup>

## INSPECT YOUR MACHINE

- Check your machine before starting it.
- Check the oil level.
- Keep guards in place and in working order.
- Make sure all nuts, bolts, etc., are securely tightened.
- Never operate the machine when it is in need of repair or is in poor mechanical condition.
- Check the air pressure in the tires.
- Replace damaged, missing, or failed parts before using it.
- Check for fuel leaks.
- Keep the machine in safe working condition.
- Do not use the machine if the engine's switch does not turn it on or off. Any gasoline powered machine that can't be controlled with the engine switch is dangerous and must be replaced.
- Regularly check to see that keys and adjusting wrenches are removed from the machine area before starting it. A wrench or a key that is left attached to a rotating part of the machine may result in personal injury.
- Avoid accidental starting. Be sure the engine's switch is off before transporting the machine or performing any maintenance or service on the unit.
- Transporting or performing maintenance or service on a machine with its switch on can lead to accidents.
- If the machine should start to vibrate abnormally, stop the engine (motor) and check immediately for the cause. Vibration is generally a warning sign of trouble.

## ENGINE SAFETY

- This machine is equipped with an internal combustion engine.
- Do not use on or near any unimproved, forest covered, or brush covered land unless the exhaust system is equipped with a spark arrester meeting applicable local, state, or federal laws.
- A spark arrester, if used, must be maintained in effective working order by the operator.
- Never start or run the engine inside a closed area. The exhaust fumes are dangerous, containing carbon monoxide, an odourless and deadly gas.
- Operate this unit only in a well-ventilated outdoor area.
- Do not tamper with the engine to run it at excessive speeds. The maximum engine speed is preset by the manufacturer and is within safety limits (see engine manual).
- Keep a Class B fire extinguisher on hand when operating this stump grinder in dry areas as a precautionary measure.

## FUEL SAFETY

Gasoline is highly flammable and explosive. You can be burned or seriously injured when handling fuel. Use extreme care when handling gasoline:

- Check fuel system on a regular basis. Look for signs of leaks, deterioration, chafed or spongy fuel hose, loose or missing fuel hose clamps, damaged fuel tank, or a defective fuel shut-off valve. Do not start grinder until needed repairs have been completed.
- Fuel is highly flammable, and its vapours can explode if ignited.
- Do not smoke, or allow sparks, open flames, or other sources of ignition near the area while adding fuel or operating the unit.
- Keep grounded conductive objects, such as tools, away from exposed, live electrical parts and connections to avoid sparking or arcing. These events could ignite fumes or vapours.
- Never store fuel or a machine with fuel in the tank inside a building where fumes could come into contact with a spark, open flame, or any other source of ignition, such as a water heater, furnace, or clothes dryer. Always store fuel in a cool, well-ventilated area.
- Store fuel in containers specifically designed and approved for that purpose. Keep the fuel in a cool, dry place in a UL-approved, tightly sealed container, and ensure it is kept out of reach of children.
- A running engine is hot enough to ignite fuel. Never add fuel or remove gas cap if engine is running or still hot. Stop the engine and allow to cool at least two minutes before adding fuel.
- Keep sources of heat, flame, or sparks away while adding fuel.
- Loosen the fuel tank cap slowly to relieve any pressure in the tank.

- Fill fuel tank outdoors - never indoors. Gasoline vapours can ignite if they collect inside an enclosure. Explosion can result.
- When refilling or draining the fuel tank, use an approved fuel storage container while in a clean, well-ventilated outdoor area.
- Don't fill to the top DO NOT overfill the gas tank. Allow at least 25 mm (1") of empty space below the fill neck to allow for fuel expansion and operation on slopes.
- Replace all fuel tank and container caps securely and wipe up spilled fuel. Never operate the unit without the fuel cap securely in place.
- Avoid creating sources of ignition near spilled fuel. If fuel is spilled, do not start the engine. Move the machine away from the spill, and ensure the area remains free of ignition sources until the vapours dissipate. Wipe the engine clean and wait 5 minutes for excess fuel to evaporate before starting. Dispose of gas-soaked rags properly.
- When fuel is spilled on your skin or your clothes, wash your skin and change clothes immediately.

## **STATIC ELECTRICITY AND FILLING GASOLINE**

Many common objects can accumulate and retain a static electric charge. Objects made of non-conductive materials (e.g. plastics) easily accumulate static electricity, as can objects made of conductive materials (e.g. metal, water), if they are not electrically grounded. The static charge on an object, such as a human body or plastic fuel tank/container, can reach several thousand volts. A static spark could occur if the charge stored on an object "jumps" to another, less charged object. Such a spark can ignite invisible gasoline vapours present during fuelling.

Static electricity has, on numerous occasions, ignited gasoline vapours during fuelling, causing serious burns to nearby persons. This may occur due to gasoline tanks or containers, flowing gasoline or static charges carried by people. To avoid static electricity during fuelling, certain steps must be followed before and during the process to minimize and safely dissipate static charge buildup.

- Never fill the grinder's gas tank directly from a service station's fuel dispenser pump - the tank is not grounded, and the high velocity flow of gasoline can cause static electricity to buildup.
- Use an UL approved portable container to transfer gasoline to the grinder's tank.
- Use a portable container made of metal or conductive plastic. It will dissipate charge to ground more readily.
- Fill container on the ground. Never fill the portable gas container while it is sitting inside a vehicle, trailer, trunk, or pick-up truck bed. ALWAYS place container on the ground to be filled.
- Before starting, touch a grounded metal object to dissipate any static charge from your body. Always do this at a safe distance from fuel sources before beginning the fuelling process.
- Always keep the fuel dispenser nozzle in contact with the portable container while filling at a service station. Avoid using the nozzle's lock-open device on the dispenser hose.

## **HAZARDS DURING FUELING**

- Ungrounded tanks or containers can build up static electricity from contact or friction during transport. This static charge may spark when the grounded gasoline nozzle is brought close to the tank or container during fuelling.
- Flowing gasoline can build up static electricity as it moves through hoses or pipes. This static charge collects in the tank or container being filled. How much charge builds up depends on the amount and speed of the gas pumped and whether the tank or container is grounded. If enough static charge accumulates, it could spark when the tank or container contacts the grounded gasoline nozzle.
- A person dispensing gasoline can carry static electricity from their car seat or electronics. This static can create a spark when their hand comes into contact with the grounded dispenser nozzle or fuel tank opening.

## PRIOR TO STARTING

- ONLY run grinder OUTDOORS and at least 6 m (20 ft) from the home, away from windows, vents and air intakes, to allow proper ventilation.
- NEVER run grinder engine inside homes, garages, sheds, or other semi-enclosed spaces. These spaces can trap poisonous gases.
- Operate OUTSIDE only - dangerous carbon monoxide exhaust! The running engine gives off carbon monoxide, a poisonous gas that can kill you. You CANNOT smell it, see it, or taste it. If you start to feel sick, dizzy, or weak while using the grinder, shut off the engine and get to fresh air RIGHT AWAY. See a doctor. You may have carbon monoxide poisoning.
- Thoroughly inspect the area in which you are working. Clear area of objects such as stones, toys, steel wire, etc. that could become caught in moving machine parts and ejected as a projectile.
- Make sure that the underneath of the stump grinder is clean and free of any debris.
- During transporting, take precautions to make sure stump grinder will not tip over and cause a fuel leak hazard.

## OPERATION SAFETY

- Never place any part of your body where it would be in danger if movement should occur during assembly, installation, operation, maintenance, repair, or moving.
- Keep hands, feet, and apparel away from drive belts, cutter wheel, and other moving parts. Never remove any drive belt or guard while the unit is operating. Contact with belt or rotating teeth will cause personal injury.
- Never smoke near the running grinder, and never operate near sources of sparks or flames.
- This product contains or emits chemicals known to cause cancer, birth defects, or other reproductive harm. Avoid inhaling exhaust fumes.
- Overexposure to machine vibration on a daily basis may lead to circulatory or nerve damage.
- Do not operate the grinder if any parts are damaged, missing, incorrectly adjusted, or broken. Always ensure that all safety covers, guards, and barriers are in place and functioning properly, and that all controls are correctly adjusted for safe operation.
- Keep the area of discharge clear of people, animals, buildings, glass, or anything else that will obstruct clear discharge, causing injury or damage.
- Exhaust from engine can be extremely hot and cause fire. Position muffler at least 2 m (7 ft) from combustible objects during operation.
- The range of temperature in which the machine is intended to operate and be stored is 5-40°C.
- Operating in wet or icy conditions could lead to losing your footing and slipping or falling.
- Keep all bystanders and animals at least 25 m (75 ft) away. If you are approached, stop the unit immediately.
- Machine can experience significant "kickback" when operating or first coming into contact with the stump.
- Stay in the OPERATOR POSITION while actuating controls.
- Never touch hot muffler or hot exhaust manifold. Exhaust and engine parts can be very hot and will burn you.
- Operate on a flat level ground.
- The grinder needs adequate, unobstructed flow of air to allow for proper cooling of engine and grinder head. Do not allow debris to accumulate and block airflow.
- Malfunction during operation. Always shut the machine off if any unusual noise or vibration occurs.
- Before adjusting, repairing or clearing jams, always turn off the grinder's engine and remove the spark plug or disconnect the spark plug wire to prevent accidental starting. Ensure that the engine is cooled before performing any diagnostics or repairs.
- DO NOT refuel the engine until it has cooled at least 30 minutes.
- Know how to stop the grinder quickly if needed by releasing the emergency stop bar. If this does not work, do the following in order until unit is stopped.
  1. Use on/off switch on engine.
  2. Engage full choke by flooding the engine.

## MACHINE USE

- Position the machine in such a way that it cannot move during maintenance, cleaning, adjustment, assembly of accessories or spare parts, as well as under storage.
- Do not change the engine governor settings or over-speed the engine. The governor controls the maximum safe operating speed of the engine.
- Do not run the engine at a high speed when you are not working.
- Do not put hands or feet near rotating parts.
- This machine has a cutter wheel capable of amputating hands and feet and throwing objects. Keep hands and feet away from openings while machine is running. Failure to observe these safety instructions could result in serious injury or death.
- Avoid contact with hot fuel, oil, exhaust fumes and hot surfaces.
- Do not touch the engine or muffler. These parts get extremely hot from operation. They remain hot for a short time after you turn off the unit.
- If the machine should start to make an unusual noise or vibration, immediately shut off the engine, disconnect the spark plug wire and check for the cause. Unusual noise or vibration is generally a warning of trouble.
- Keep the engine and muffler free of grass, leaves, excessive grease or carbon build up to reduce the chance of a fire hazard.
- Allow the engine to cool for at least five minutes before doing maintenance or making adjustments. A hot engine can be a fire hazard.
- Shut off fuel supply. Make sure gasoline shut-off valve is in the OFF position.
- Prevent accidental starting. When grinder is not in use, remove key from starter (electric start engines) and secure in a safe location, or remove spark plug in order to ensure that grinder cannot be started in a storage location or by untrained persons.
- Use only attachments and accessories approved by the manufacturer. Failure to do so can result in personal injury.
- Keep the grinder in a location away from sources of heat, open flames, sparks, or pilot lights, such as water heaters, space heaters, furnaces, clothes dryers, or other gas appliances - even if the grinder's gas tank is empty. Residual gasoline could still ignite.
- Never douse or squirt the unit with water or any other liquid. Keep handles dry, clean and free from debris. Clean after each use.
- When storing the machine, ensure it is out of the reach of children. Do not allow individuals who are unfamiliar with the machine or these instructions from operating it. This machine can be dangerous when used by an untrained user.
- Observe proper disposal laws and regulations for gas, oil, etc. to protect the environment.
- Start the grinder every four weeks to remove any moisture that may accumulate in the windings. If you can't operate the grinder regularly, prepare it for long-term storage.

## PROHIBITION AGAINST MODIFICATIONS

Never modify or alter the grinder in any way. Modifications can create serious safety hazards and will also void the warranty.

- Fuel/exhaust system. Never modify the exhaust system, fuel tanks, or fuel lines. Carbon monoxide poisoning, fire, or explosion could result.
- Guards. Do not operate grinder unless all guards and cover shields, which prevent access to moving parts and pinch points, are in place. Failure to guard the power transmission mechanisms may result in serious injury or death.

## INSPECTION / MAINTENANCE

- Turn off grinder. Always turn off grinder and remove spark plug or spark plug wire before working on the engine or grinder to prevent accidental starting.
- Some parts of this machine are made of plastic or rubber and should be kept away from chemicals.
- Do not touch hot muffler. Muffler will be hot even if unit is stopped. Allow unit to cool before servicing.
- Never cover the machine while the muffler is still hot.
- Do not alter or adjust any part of the stump grinder or its engine that is sealed by the manufacturer or distributor. Only a qualified service technician may adjust parts that increase or decrease governed engine speed.
- To maintain your machine, check for any misalignment or binding of any moving parts. Parts that are broken or worn down that may affect the machine's operation should be replaced before use. Many accidents are caused by poorly maintained equipment. Make sure all guards and shields are replaced after servicing the grinder.
- If a part needs replacement, only use parts that meet the manufacturer's specifications. Replacement parts that do not meet specifications may result in a safety hazard or poor operation of the grinder and will void the warranty.



**IF ANYTHING THAT MIGHT DAMAGE EQUIPMENT HAPPENS DURING OPERATION, THE EQUIPMENT MUST BE INSPECTED TO DETECT AND ASSESS POSSIBLE DAMAGES. DAMAGES (FRACTURES IN THE STRUCTURE OR WELD, DEFORMED DETAILS) MAY HARM PROPERTY AND HEALTH OF PEOPLE. DO NOT CONTINUE OPERATING THE EQUIPMENT BEFORE ELIMINATION OF DAMAGES.**

## ABOUT YOUR GRINDER

### Owner/Operator/Renter Training

Read and follow all instructions and safety precautions presented throughout this manual. Keep this manual for reference and review. If the owner of this unit is different than the operator, give a copy of this manual to any operator to read.

### Rental Companies

All persons to whom you rent/loan this grinder must have access to this manual and read it. Check the tube on the side of the unit to make sure a manual is inside. Advise all persons who will operate the machine to read it. You should also provide personal instruction on how to safely operate the grinder and remain available to answer any questions a renter/borrower might have. If videos are available, have renter watch training video.

### Engine Instructions

For detailed engine operation and maintenance information, always refer to the engine Owner's Manual furnished with the grinder.

### Product Suitability

Before using, the user shall determine the suitability of this product for this intended use and assumes liability therein.











Your stump grinder can be used to remove tree stumps and exposed root systems close to ground level. By moving the blade in sweeping movements laterally over the top and front of the stump, you can gradually grind it away. Make sure you completely read and understand this manual before using the grinder for the first time. If you have any question, contact your retail or rental dealer or manufacturer.

The supplier is constantly improving its products. The specifications outlined herein are subject to change without prior notice or obligation. The purchaser and/or user shall assume liability for any modification and/or alterations of this equipment from original design and manufacture.

# SAFETY LABELS

The warning labels shall be present on your stump grinder. These represent important information about the product or instructions on its use. If any of these labels is missing or damaged, contact the dealer of the stump grinder to replace the missing labels with new ones.

## MEANING OF WARNING LABELS

|   |   |
|---|---|
|    | <b>Read these instructions for use carefully.</b>   |
|    | <b>Wear eye protection.<br/>Wear hearing protection.</b>  |
|    | <b>Wear protective gloves.</b>  |
|    | <b>Wear safety footwear.</b>  |
|    | <b>Do not remove or tamper with the protection and safety devices.</b>                                  |
|   | <b>Do not touch parts which are hot from operation. Serious burns may result.</b>                       |
|  | <b>No smoking, No sparks, No flames.</b>  |
|  | <b>Keep your hand and feet away from moving parts.</b>  |
|  | <b>Thrown Objects.</b>  |
|  | <b>Besure the engine's switch is off before transporting the machine or performing any maintenance.</b> |
|  | <b>Keep bystanders away.</b>  |

# PRODUCT DESCRIPTION

A towable stump grinder is a tool specifically designed for the effective and quick removal of tree stumps from the ground. The powerful 14hp Briggs & Stratton engine and 8 carbide teeth ensure excellent cutting results, allowing stumps to be easily cut up to 300 mm above ground and 230 mm below ground, making it suitable for removing stumps of any diameter. The chassis lock lever simplifies manoeuvring and allows grinding from different angles.

The compact and lightweight design allows it to be towed by an ATV or a smaller tractor. It is ideal for transporting and manoeuvring in narrow spaces like forests or gardens. A towable stump grinder is an efficient and convenient tool for removing stumps in challenging terrains or areas that larger machines can't access. Stump grinder is capable of removing the toughest and most awkward tree stumps with minimal effort.

The stump grinder is equipped with the following:

- Strong steel structure and powder coat finish
- Powered by a 14HP Briggs & Stratton gasoline engine
- 8 replaceable carbide teeth
- Towbar with a 50mm (2") coupler and trolley wheel
- Multi-position adjustable handle
- Adjustable rotation handle
- Wheel lock with brake lever
- Throttle control lever
- Emergency stop bar

| <b>Stump Grinder SG-8</b>       |  |
|---------------------------------|--|
| <b>Engine</b>                   | Briggs & Stratton                      |
| <b>Type of fuel</b>             | Gasoline                               |
| <b>Starting</b>                 | Recoil                                 |
| <b>Displacement</b>             | 420 cc                                 |
| <b>Net power</b>                | 13,5 HP                                |
| <b>Operating RPM</b>            | 3600 RPM                               |
| <b>Assembled weight</b>         | 104 kg (230 lb)                        |
| <b>Assembled size</b>           | 1730 x 760 x 1150 mm (68" x 30" x 45") |
| <b>Packing dimensions</b>       | 1020 x 700 x 650 mm (40" x 28" x 26")  |
| <b>Belt</b>                     | 2 x V-belts (Kevlar)                   |
| <b>Clutch</b>                   | Centrifugal clutch                     |
| <b>Wheel tire</b>               | All-terrain wheels 145/70-6            |
| <b>Towbar</b>                   | 50 mm (2") coupler and trolley wheel   |
| <b>Multi position handlebar</b> | Adjustable to different positions      |
| <b>Chassis lock lever</b>       | Adjustable to different angles         |
| <b>Brake lever</b>              | 2 x wheel lock                         |
| <b>Throttle control lever</b>   | Engine speed control                   |
| <b>Safety feature / Stop</b>    | Emergency stop bar                     |
| <b>Cutter wheel</b>             |  |
| <b>Cutting blade</b>            | 8 pcs with carbide tips (42CrMo)       |
| <b>Cutting wheel dia.</b>       | 240 mm (9,5")                          |
| <b>Cutting wheel thickness</b>  | 12 mm (0,47")                          |
| <b>Cutting capacity</b>         |  |
| <b>Rotation angle</b>           | 65° to left and right                  |
| <b>Working width</b>            | 800 mm (32") / 65°                     |
| <b>Cutting height</b>           | 300 mm (12") in above ground           |
| <b>Cutting depth</b>            | 230 mm (10") in below ground           |

Table 1: Technical specification of the Stump Grinder

# OPERATION

Before operating the machine, make sure you have completed the following:

- Wear personal protection equipment (PPE);
- Check/add oil;
- Check/add gasoline;
- Inspect the fuel system for leaks;
- Check controls;
- Inspect cutting teeth;
- Lock the handle bar;
- Work during daylight;
- Clear the area of people and objects;
- Mark underground utilities;
- Trim the stump with a saw;

Each of these procedures is discussed in detail below.

## CHECK/ADD OIL TO ENGINE



**CAUTION: Add engine crankcase oil. You must add the correct amount of oil to engine crankcase or engine will be damaged beyond repair.**



**WARNING: Burn Hazard.  
Never open oil fill port while engine is running.  
Hot oil can spray over face and body.**

1. Make sure the stump grinder is on a flat, level surface.
2. Remove the oil fill cap/dipstick to add oil.
3. Using a funnel, add oil up to the FULL mark on the dipstick. (See engine manual for oil capacity, oil recommendation, and location of fill cap.).

## CHECK/ADD GASOLINE TO ENGINE



**WARNING: Gasoline fire/explosion hazard**

Gasoline is highly flammable and explosive. Heat, sparks and flames can ignite gasoline vapours, which can become widespread during fuelling. A flash fire ignition and/or explosion could result and cause serious injury or death. The following conditions could result in gasoline ignition/explosion:

- Gas vapor collection inside enclosures.
- Static electric sparks
- Sparks from electric wiring, batteries, or running engines.
- Sources of heat (such as a hot engine or exhaust).
- Open flames, including pilot lights.



**Gasoline is highly flammable and explosive. You can be burned or seriously injured when handling fuel. Use extreme care when handling gasoline.**



**Fill the fuel tank outdoors, never indoors. Gasoline vapours can ignite if they collect inside an enclosure. Explosion can result.**

## **!! DO NOT OVERFILL !!**



**This equipment and/or its engine may include evaporative emissions control system components, required to meet EPA and/or CARB regulations, that will only function properly when the fuel tank has been filled to the recommended level. Overfilling may cause permanent damage to evaporative emissions control system components. Filling to the recommended level ensures a vapor gap required to allow for fuel expansion. Pay close attention while filling the fuel tank to ensure that the recommended fuel level inside the tank is not exceeded. Use a portable gasoline container with an appropriately sized dispensing spout when filling the tank. Do not use a funnel or other device that obstructs the view of the tank filling process.**

1. The engine must be off and allowed to cool at least two minutes before adding fuel.
2. Remove the fuel filler cap and fill the tank. (See engine manual for fuel capacity, fuel recommendation, and location of fuel cap.)
  - DO NOT fill the gas tank to the top. Gasoline may spill when operating on a slope.
  - DO NOT overfill the gasoline tank. Allow at least 25 mm (1") of empty space below the fill neck to allow for fuel expansion.
3. Reinstall the fuel cap and tighten. Always clean up spilled fuel.

## **REFUELING**

1. Before removing the gas cap, turn the engine off and allow it to cool for at least two minutes. A running or hot engine can ignite fuel.
2. Remove grinder gasoline cap.
3. Add gasoline through the fill opening.
  - Use only a portable gasoline container to transfer gasoline to the grinder's tank.
  - Be aware of the safety warnings and instructions below to avoid static electricity hazards.
  - Do not overfill.



### **WARNING: Static electric spark hazard**

A static electric spark can explosively ignite gasoline vapor, resulting in a flash fire that could cause serious injury or death. See the "HAZARDS DURING FUELING" section.

4. Clean up gasoline spills / splashes immediately.
  - If possible, move the grinder away from spilled gasoline on the ground.
  - Wipe up spilled gasoline and wait 5 minutes for excess gasoline to evaporate before starting engine.
  - Gasoline-soaked rags are flammable and should be disposed of properly.
  - If gasoline is spilled on your skin or clothes, change clothes and wash skin immediately
5. Replace gasoline cap securely before starting engine.

Store extra gasoline in a cool, dry place in a tightly sealed container.

Filling towable units or portable containers at service stations: Even if you have a towable unit, avoid static electric sparking while filling the gasoline tank.

- Never fill the grinder's gas tank directly from the fuel pump. The grinder's tank is not grounded and high velocity flow from the pump can cause static electricity build-up. Use a portable container to transfer gas to the grinder's tank.
- Use a portable container made of metal or conductive plastic, as these materials dissipates static charge to ground more effectively.
- Never fill a portable gas container while it is sitting inside a vehicle, trailer, trunk, or pick-up truck bed. ALWAYS place the container on the ground to be filled.
- Keep the nozzle in contact with container while filling. Do not use a nozzle lock-open device.

## INSPECT FUEL SYSTEM/CHECK FOR LEAKS



**WARNING: Fuel leak hazard!**

Inspect fuel system & check for leaks BEFORE starting grinder. A leaking fuel line no matter how small can be the source of a fire or explosion when starting or operating the engine.

Inspect the entire fuel system. Look for: Signs of leaks or deterioration, chafed or spongy fuel hose, loose connections, loose or missing fuel hose clamps, damaged gasoline tank, or defective gasoline shut-off valve.

If grinder is in an enclosed area and you smell gas, DO NOT start engine! DO NOT light a match. DO NOT flip on an electrical switch. Exit area immediately leaving doors open and call fire department

### CHECK CONTROLS

- All guards are in place and tight.
- The operator's emergency stop bar moves freely.
- Inspect tires and rims for looseness, damage, and proper tire inflation.

### INSPECT CUTTING TEETH

Inspect cutting teeth for tightness and sharpness. Only use factory-approved parts for repair.

### WORK DURING DAYLIGHT

Only use the machine in daylight or in well-lit conditions. Never operate the grinder after dark.

### CLEAR AREA

Dig away the earth and remove any stones near the tree stump or roots that may interfere with your work.

### TRIM STUMP WITH SAW

Cut or trim the stump preferably to ground level using a power saw.

## LOCKING HANDLEBAR

The multi-position handlebar can be easily folded down when not in use by simply releasing a handle. This feature allows the bar to be quickly and conveniently collapsed, making the stump grinder more compact for storage and transport.

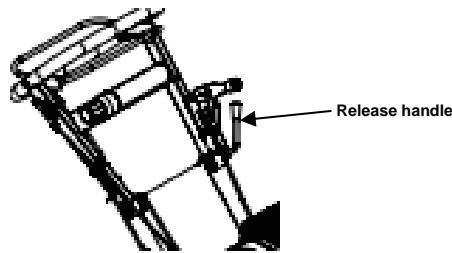

## STARTING THE GRINDER



**Never attempt to use the grinder without proper protective equipment, particularly eye protection and a full-face shield.**

After you have completed the pre-start checklist and procedures, you are ready to start the grinder. The following directions details how to start the engine of your grinder.

Note: For additional engine starting instructions see your gasoline engine manual.

Start the grinder using the following steps:



**Stay in the OPERATOR POSITION (behind the machine) while actuating controls. Never leave grinder unattended.**

1. Lock multi position handle in the upright position.
2. Use the chassis lock lever to secure the stump grinder in a straight position.
3. Place stump grinder into position with cutting wheel near the front-top edge of the stump. Make sure the machine cannot move.
4. Engage the brake lever to lock the wheel brake. For tighter brake adjustment, turn knob on top of brake lever (see "MAINTENANCE" section for instructions).
5. Open the fuel shut-off valve.

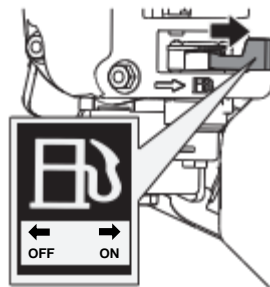

6. Move the choke lever to the CLOSED position.  
**NB! If the engine is hot, closing the choke is not necessary.**

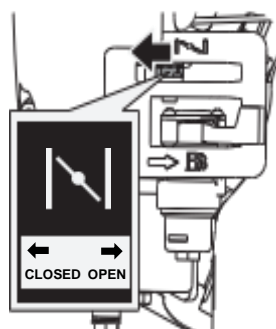

7. Move the throttle control lever slightly to the SLOW speed.
8. Check that the ignition switch on the engine is in the ON position.
9. Press and hold the handlebar and the emergency stop bar.
10. Start the engine using the pull start. Pull the recoil starter until engine compression has become difficult to pull. Let the recoil return to the home position, then pull quickly to start the engine. Repeat steps as needed. Fully open the choke and set the throttle to the FAST position, before operating the unit.
11. Push down on the handlebar to lift the cutter wheel off the ground. This will engage the centrifugal clutch and cause the cutter wheel to start rotating.



**Rapid retraction of the starter cord (kickback) will pull your arm toward the engine faster than you can let go. Broken bones, fractures, bruises, or sprains could result.**



**A rotating cutting wheel is very dangerous. Stay at the controls and keep others away until you are sure the blades have come to a complete stop.**

## STOPPING THE GRINDER

To stop the engine in an emergency, simply release emergency stop bar. Under normal conditions, use the following procedure:

1. Use the brake lever to lock the wheels, particularly if you are on an incline.
2. Move the throttle lever to the SLOW (←) position.
3. Let the engine idle for one or two minutes.
4. While holding cutting wheel off ground, release the emergency stop bar. The engine will stop. Wait until the cutting wheel completely stops. Lower the cutting wheel so it is resting against the ground.
5. Press the engine switch to the OFF position.
6. Turn the fuel valve lever to the OFF position.
7. Allow the engine to cool for at least 1 hour before releasing brake and moving to storage or transporting. Remove the engine's spark plug. A hot engine can be a fire hazard.



**Sudden stopping at a high speed under a heavy load is not recommended. Engine damage may result.**



**Do not move the choke control to CLOSE to stop the engine. Backfire or engine damage may occur.**

## GRINDING THE STUMP



**WARNING: Flying debris hazard**

- Stones, chips, and debris can cause serious injury or property damage.
  - Debris can fly 25 m (75 ft) in any direction out of the chute. They can bounce off any fixed objects as well and hit operator, bystanders or breakable object.
1. After the engine warms up, pull the throttle lever to accelerate engine speed.
  2. Set/engage the brake.
  3. Pivot the grinder toward the side of the stump, with a fairly light touch feed straight into the stump. As soon as you feed in, start to swing to the side until you feel the wheel drop off the edge of the stump.
  4. Change direction and swing back the other way until you feel it reach the other edge of the stump. As you swing to the side listen to the engine. Provide enough feed to give it a moderate load. If you hear any belt or clutch squealing, you are pushing too hard. If you cannot swing it to the side, raise the grinder up. (You can cut roots off by plunging straight through them.)



**WARNING: Never attempt to cut on a slope exceeding 15°**

Exercise caution when cutting stumps on an incline, as the machine may shift or slide unpredictably. Never attempt to cut with the machine uphill or downhill from you as it may slide toward you, or you may fall toward the machine. Cut only on a slope from the side



**WARNING: Rotating cutter wheel**

Keep hands and feet away. Contact with wheel rotating teeth will cause serious personal injury.

- When grinding larger stumps, chips may begin to build up under the wheel.
- Release brake and pull machine towards you so that the "chip pile" is directly under the cutting wheel.
- Drop cutter wheel down on "chip pile", material will be discharged from machine area.

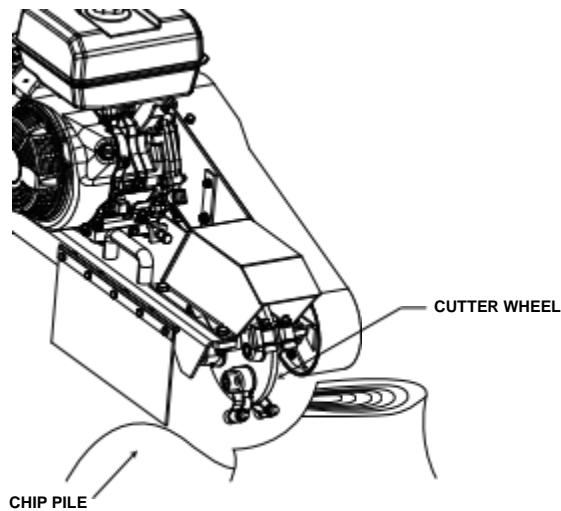

On these large stumps, DO NOT allow grinder wheels to drop into stump hole. If a hole is in the way of your progress, fill it with chips or change position.



**Stop engine and set brake before leaving operator's position.  
KEEP BRAKE ENGAGED except when changing locations.**

- When finished, stop the engine.
- Pull machine away from stump, and rack chips away from stump.

## **IDLE SPEED**





Set the throttle control lever to the SLOW position to reduce stress on the engine when grinding is not being performed. Lowering the engine speed will help extend the life of the engine, as well as conserve fuel and reduce noise level.

## **TRANSPORTING**

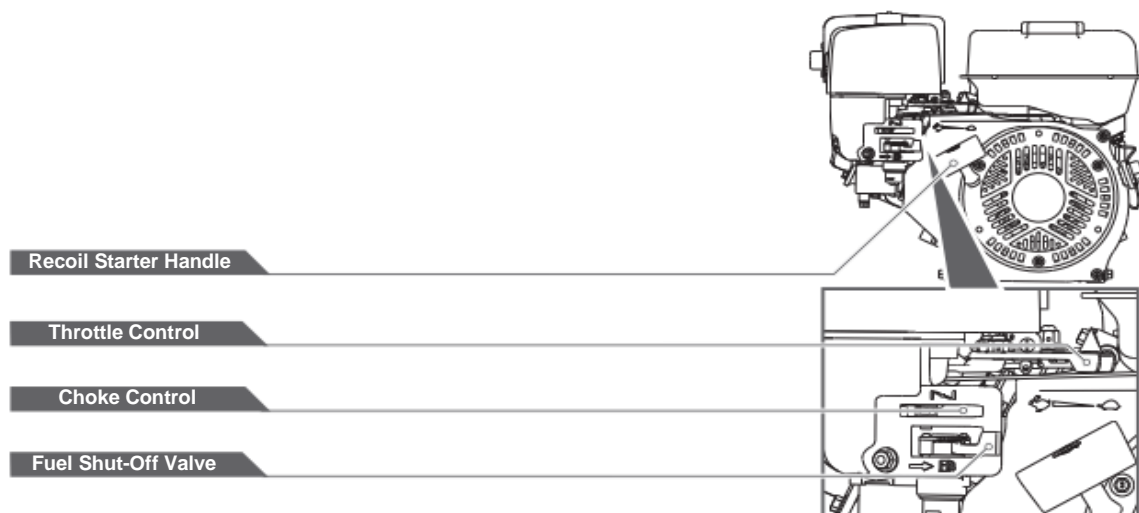
Your stump grinder is equipped with two large pneumatic wheels and one trolley wheel for easy movement by hand. To move the unit, grip the handle and tilt the stump grinder slightly.

# KNOW YOUR MACHINE



- Recoil starter handle → The handle is used to start the engine.
- Fuel shut-off valve → CLOSED - use this position to service, transport, or store the unit.  
OPEN - use this position to run the unit.
- Choke control → The choke control is used to choke the carburetor and assist in starting the engine. The choke control slides between the CHOKE CLOSED  and CHOKE OPEN  positions.
- Throttle control → The throttle control regulates the speed of the engine and will shut-off the engine when it is moved to the STOP position. The throttle control moves between FAST  , SLOW  , and STOP positions.

# SPECIFICATION

| Pos. | Description                      | Amount |
|------|----------------------------------|--------|
| 1    | Body assembly (main machine)     | 1      |
| 2    | Base plate                       | 1      |
| 3    | Multi-position handlebar         | 1      |
| 4    | Towbar                           | 1      |
| 5    | Wheels 145/70-6                  | 2      |
| 6    | Trolley wheel                    | 1      |
| 7    | Rubber baffle 1                  | 1      |
| 8    | Rubber baffle 2                  | 1      |
| 9    | Rubber baffle 3                  | 1      |
| 10   | Rubber baffle 4                  | 1      |
| 11   | Cable tie 4,7x366 (PM.11.00.009) | 2      |
| 12   | Square lock pin 12x80            | 1      |
| 13   | Screw M6X40                      | 2      |
| 14   | Hex bolt M8x20                   | 13     |
| 15   | Hex bolt M8x45                   | 1      |
| 16   | Hex bolt M10x25                  | 4      |
| 17   | Hex bolt M12x45                  | 4      |
| 18   | Hex bolt M16x360 with handle     | 1      |
| 19   | Flat washer 6                    | 2      |
| 20   | Flat washer 8                    | 10     |
| 21   | Flat washer 10                   | 4      |
| 22   | Spring washer 12                 | 4      |
| 23   | Flat washer 12                   | 4      |
| 24   | M6 lock nut                      | 2      |
| 25   | M8 nut                           | 1      |
| 26   | M8 lock nut                      | 18     |
| 27   | M10 lock nut                     | 4      |



# ASSEMBLING GUIDE

**NB! Personal protective equipment must be used when assembling the stump grinder!**



## TOOLS REQUIRED FOR INSTALLATION:

- Hex key 4 mm
- Spanner 10 mm
- Spanner 13 mm
- Spanner 14 mm
- Spanner 16 mm
- Spanner 17 mm
- Spanner 18 mm
- Socket wrench 10 mm
- Socket wrench 13 mm
- Socket wrench 14 mm
- Socket wrench 16 mm
- Socket wrench 17 mm
- Socket wrench 18 mm

### Step 1

Carefully unpack the stump grinder using scissors or a knife to cut and remove the straps.

### Step 2

Secure the wheel (Pos.5) to the axle using Ø8 mm flat washers (Pos.20) and M8 lock nuts (Pos.26) on both sides.



### Step 3

Attach the base plate (Pos.2) to the body using M12x45 hex bolts (Pos.17), Ø12 mm flat washers (Pos.23) and Ø12 mm spring washers (Pos.22).



### Step 4

Mount the multi-position handlebar (Pos.3) to the base plate. For fastening, insert the M16x360 hex bolt (Pos.18) from the right side and secure it with the handle.



## Step 5

Attach the brake cable to the brake lever using M8x45 hex bolt (Pos.15), Ø8 mm flat washers (Pos.20) and M8 lock nut (Pos.26). Tighten the bolt slightly to ensure the lever moves freely.



## Step 6

To adjust braking tension, loosen the bolt on top of the brake lever. Turn the knob clockwise to increase tension or counterclockwise to decrease it, then retighten the bolt. Also, you can adjust the tension by changing the position of the cable underneath the stump grinder.

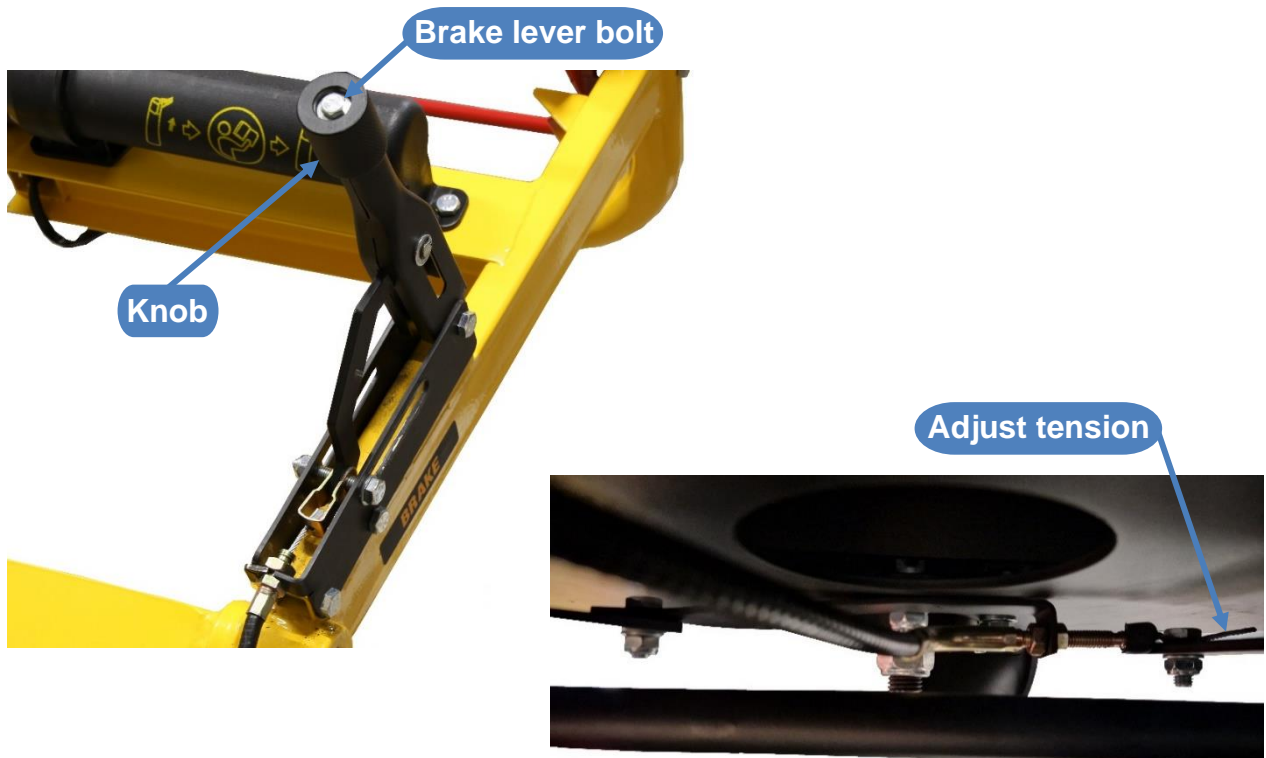

## Step 7

Attach the chassis lock lever to the handlebar. For fastening use Ø8 mm flat washer (Pos.20), M8 nut (Pos.25) and M8 lock nut (Pos.26).



## Step 8

Secure the cable to the base plate bracket, cable holder should be in the topmost position. Bottom nut should be flush with bottom of the cable sleeve! Ensure the chassis lock lever is functioning correctly. If necessary, adjust the height of the pin. For that, loosen the nut on top of the pin, hold the threaded part of the cable and turn the locking pin. After adjustments tighten the lock nut on top of the pin.

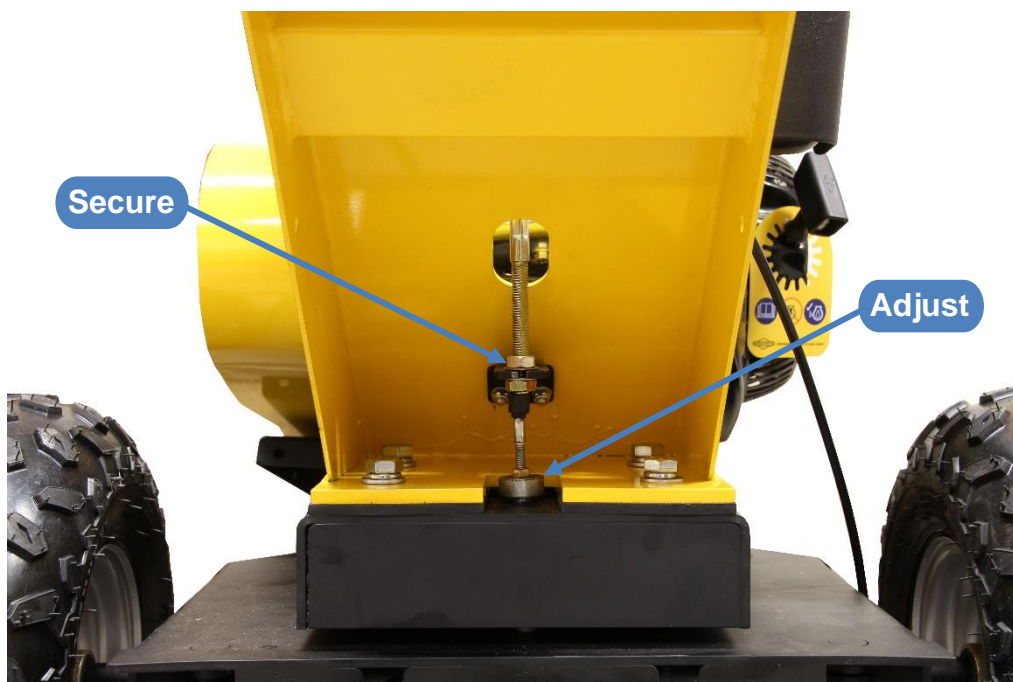

## Step 9

Mount the throttle control lever to the handlebar. For fastening use M6x40 screws (Pos.13), Ø6 mm flat washers (Pos.19) and M6 lock nuts (Pos.24).



## Step 10

Connect the stop-switch plug to the stump grinder.

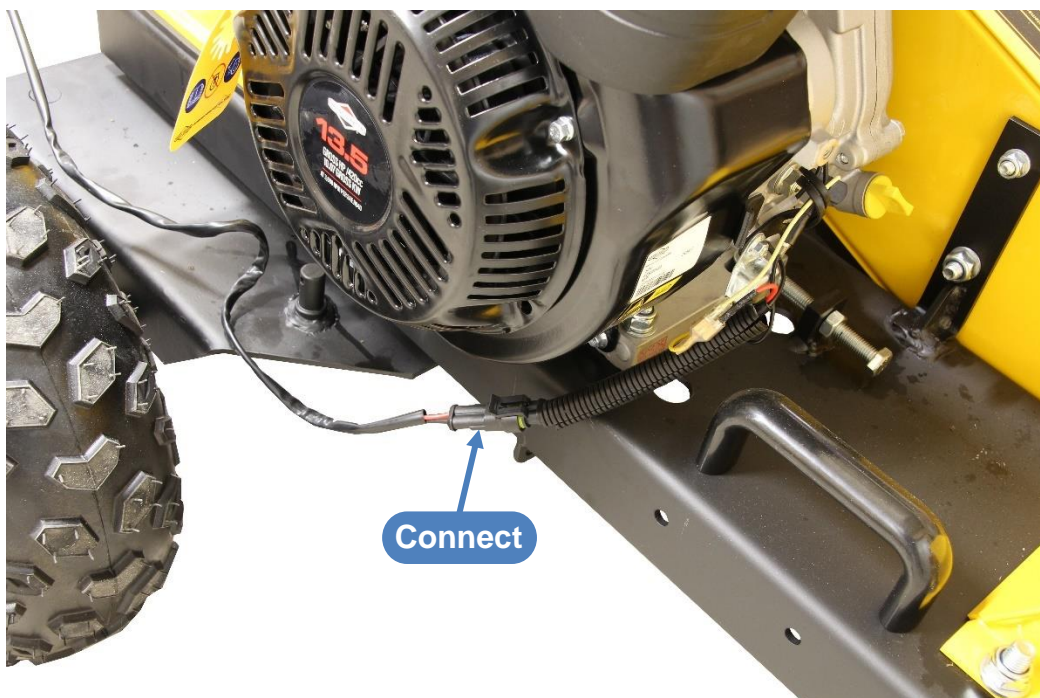

### Step 11

Guide the stop-switch cable and the throttle control lever cable through the base plate clamp, then tighten the bolt. Secure them with cable ties (Pos.11). Make sure the cables do not hit muffler!



### Step 12

Attach the trolley wheel (Pos.6) to the towbar (Pos.4). For fastening use M10x25 hex bolts (Pos.16), Ø10 mm flat washers (Pos.21) and M10 lock nuts (Pos.27).

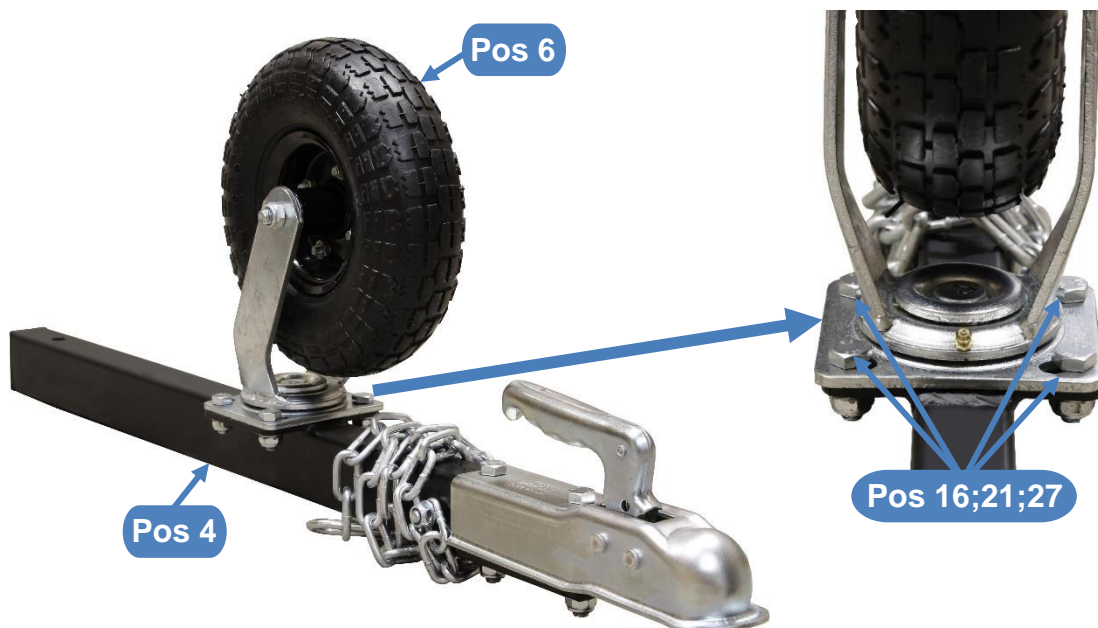

### Step 13

Use the 12x80 square lock pin (Pos.12) to connect the towbar to the main body of the machine.



### Step 14

Install the rubber baffles (Pos.7; Pos.8; Pos.9; Pos.10) to the main body of the machine. For fastening use M8x20 hex bolts (Pos.14), Ø8 mm flat washers (Pos.20) and M8 lock nuts (Pos.26).

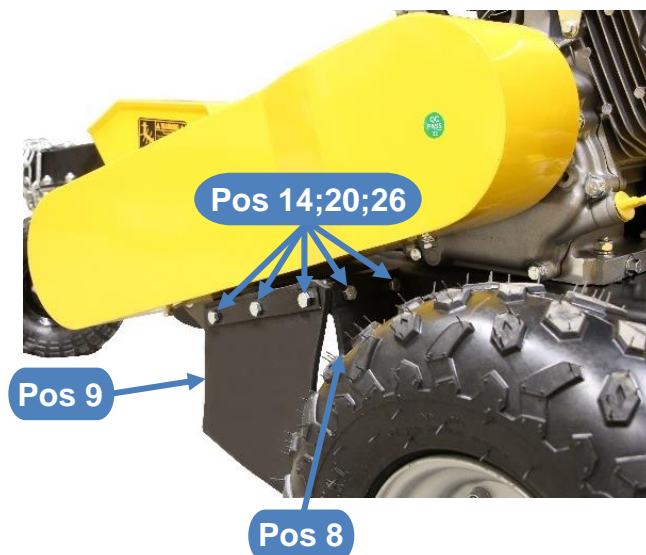
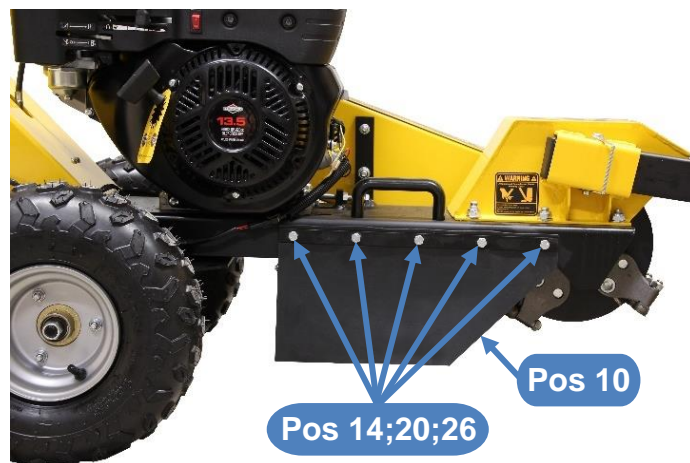
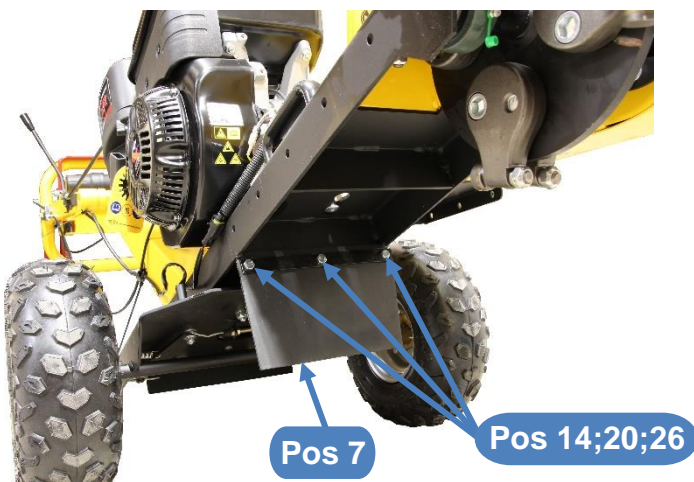

# MAINTENANCE

Regularly perform the maintenance outlined in this manual to keep the grinder in safe working condition. Maintaining your stump grinder will ensure long life to the machine and its components.



**Shut down the engine, wait for all moving parts to come to a complete stop, remove the spark plug wire, and then wait five minutes before performing maintenance on the stump grinder.**



**Never use a pressure washer to clean your stump grinder. Water can penetrate tight areas of the unit and cause damage to spindles, pulleys, bearings, or the engine.**

## PREVENTIVE MAINTENANCE

1. Turn off the engine. The muffler will remain hot even after the unit is stopped, so the engine must be cool. Allow the unit to cool before servicing.
2. Keep the engine's throttle lever in its SLOW position and remove the spark plug wire from the spark plug and secure.
3. Inspect the general condition of the stump grinder. Check for loose screws, misalignment or binding of moving parts, cracked or broken parts/guards/shields and any other condition that may affect its safe operation. If a part needs replacement, only use factory approved repair parts. Replacement parts that do not meet specifications may result in a safety hazard or poor operation of the grinder and will void the warranty. The replacement of electrical parts should be performed only by a qualified electrical service technician.
4. Remove all debris from the stump grinder with a soft brush, vacuum, or compressed air. Then use a premium quality lightweight machine oil to lubricate all moving parts.
5. Reconnect the spark plug wire.

## REGULAR MAINTENANCE CHECKLIST

| Procedure  | Before Each Use                           | Every 10 Hours | Every 20 Hours | Every 40 Hours |
|--|---|----------------|----------------|----------------|
| Check engine oil level                             | •   | •              | •              | •              |
| Check gasoline amount                              | •   | •              | •              | •              |
| Inspect fuel system / check for leaks              | •   | •              | •              | •              |
| Check general equipment condition                  | •   | •              | •              | •              |
| Check cutter teeth sharpness                       | •   | •              | •              | •              |
| Check emergency stop bar condition                 | •   | •              | •              | •              |
| Check that brake lever functioning properly        | •   | •              | •              | •              |
| Check that chassis lock lever functioning properly | •   | •              | •              | •              |
| Check that throttle control functioning properly   | •   | •              | •              | •              |
| Check that warning decals are legible              | •   | •              | •              | •              |
| Check tires pressure                               | •   | •              | •              | •              |
| Check rubber guards condition                      | •   | •              | •              | •              |
| Check wires and cables condition                   | •   | •              | •              | •              |
| Check for any loose nut and bolts                  |   | •              | •              | •              |
| Check and grease shaft bearings                    |   |                | •              | •              |
| Check belts tension and condition                  | 1 <sup>st</sup> time 1 hour               |                | •              | •              |
| Replace drive belts                                |   |                |                | •              |
| Perform engine maintenance                         | see the engine manufacturer's user manual |                |                |                |



**IMPORTANT: If a part needs replacement, only use parts that meet the manufacturer's specifications. Replacement parts that do not meet specifications may result in a safety hazard or poor operation of the grinder.**

## PERFORM ENGINE MAINTENANCE

Perform engine maintenance as specified in the engine owner's manual. Engine maintenance items include:

- Oil change;
- Air filter check/replacement;
- Spark plug cleaning and replacement;
- Fuel filter check/replacement;
- Fuel tank cleaning.

## INSPECT FUEL SYSTEM / CHECK FOR LEAKS

Inspect the fuel system and check for leaks on a regular basis. Look for:

- Signs of leaks or deterioration
- Chafed or spongy fuel hose
- Loose connections
- Loose or missing fuel hose clamps
- Damaged gasoline tank or defective gasoline shut-off valve.

## GREASE

Grease the cutter wheel shaft bearings by pumping grease into the zerks located on the bearing housing. Lubricate them after every 20 hours of use. Although the bearings are greased when new, it's recommended to grease them after a few hours of use initially. One or two pumps of grease is usually sufficient. Be cautious not to over-grease, as excessive lubrication can damage the bearings.

| Grease specifications |  |
|-----------------------|--|
| Grease type           | Lithium complex                                    |
| NLGI Grade            | #2   |
| Dropping point        | 230°C (446°F)                                      |
| Additives             | Corrosion and oxidation inhibitors,<br>EP optional |
| Viscosity index       | 80 minimum   |

## TEETH WEAR

Check the wear on the teeth before each use. When it's time for replacement, inspect the entire set of teeth. If any tooth is partially worn or has a missing piece, it should be replaced. When the first cutting edge is becoming blunt, the entire set of teeth should be rotated by one-third of a turn. Using blunt teeth will reduce cutting efficiency and increase fuel consumption.

For instructions on installing the teeth, see the "TEETH AND HOLDER REPLACEMENT" section.

## CHECK AND ADJUST BRAKE

Check that the brake is functioning properly.

1. Lock the wheels using the brake lever.
2. Push down on the handlebar so that the cutter wheel is off the ground
3. Push or pull the stump grinder - if the brake is loose, the wheel will rotate.

To adjust the braking tension, see step 6 in the "ASSEMBLING GUIDE" section.

## STOP-SWITCH ADJUSTMENT



**Never attempt to alter, modify or override this switch.**

If stop-switch ever needs to be replaced or adjusted, follow these steps:

1. Loosen bolts, but do not remove.
2. To set the interaction distance, grip the multi-position handlebar and emergency stop bar together and adjust the switch button.
3. Tighten bolts.
4. Verify the operability of stop-switch before operating machine. Release the emergency stop bar and listen for a "CLICK" to confirm the switch is set correctly.

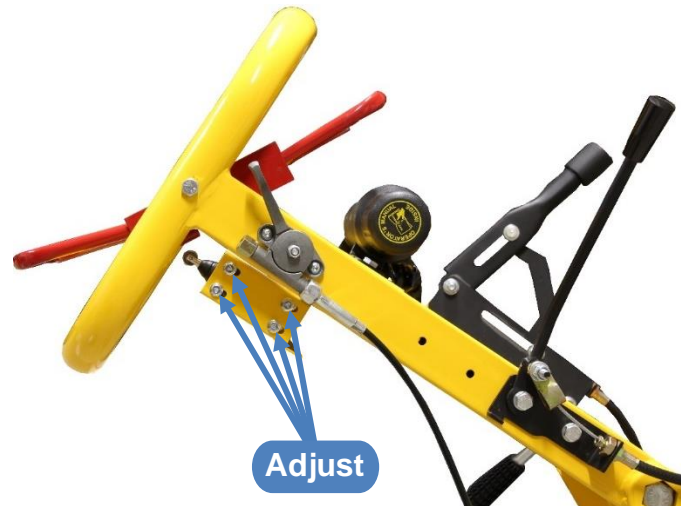

# STORAGE

The stump grinder should be stored in a clean, dry area and free of pests and animals. Keep it away from sources of heat, open flames, sparks, or pilot lights, even if the grinder's gas tank is empty as residual gasoline could ignite. Store it away from extreme high or low temperatures. Cover the grinder for extra protection.

Plan on starting the engine at least monthly unless the grinder is prepared for long term storage. If your stump grinder will not be used for more than 30 days, follow the steps below to prepare your unit for storage:

1. Start the engine and allow it to run until it stops. This ensures no fuel is left in the carburettor and helps prevent deposits from forming inside, which can damage the engine.
2. Drain the fuel tank completely. Stale fuel has high gum content and can clog the carburettor and restrict fuel flow.
3. Drain the oil from the engine while it is still warm. Allow the engine to cool at least 1 hour before storing it. Remove the spark plug and put high-quality engine oil into the cylinder. Pull the starter rope slowly to distribute the oil. Replace the spark plug.
4. Use clean cloths to remove all grease, dirt, mud and other foreign matter from the machine and keep the air vents free from obstructions. Touch up any paint damage to prevent rust.
5. Inspect the machine for worn or damaged parts and tighten any nuts or screws that may have become loose. Pay particular attention to the cutting teeth.
6. Store your stump grinder in an upright position in a clean, dry building with good ventilation.



**Do not use strong detergents or petroleum-based cleaners when cleaning plastic parts. Chemicals can damage plastics.**



**Do not store your stump grinder with fuel in a non-ventilated area where fuel fumes could reach flames, sparks, pilot lights or any ignition sources.**

**Use only approved fuel containers.**

## START GRINDER EVERY 4 WEEKS

If you decide not to drain all fuel from the machine, the stump grinder should be started regularly. At least every 4 weeks, start the engine and let it run for 10 to 15 minutes. Monthly starting of the grinder will dry out any moisture that has accumulated, lubricate cylinders, and clean out old gas in the carburettor. Moisture, old gas, and dry mechanical parts cause deterioration in stored engines.

# TROUBLESHOOTING

Stop the stump grinder immediately if any trouble occurs. The inspection must not commence until the moving parts of the stump grinder have fully stopped. If the trouble has not been identified, please contact the retailer or manufacturer. Be sure to inform them of the detailed malfunctions and unit model.

Troubleshooting and repairs of the machine must be carried out by qualified operators/professionals.

| Trouble  | Possible cause  | Solution   |
|--|---|--|
| Engine fails to start  | <ol style="list-style-type: none"> <li>1) Spark plug wire is disconnected</li> <li>2) Out of fuel or stale fuel</li> <li>3) Engine and/or Fuel valve is not in ON position</li> <li>4) Choke lever is not in CLOSE position</li> <li>5) Blocked fuel line</li> <li>6) Fouled spark plug</li> <li>7) Engine flooding</li> </ol>    | <ol style="list-style-type: none"> <li>1) Attach spark plug wire securely to spark plug</li> <li>2) Fill with clean, fresh gasoline</li> <li>3) Engine and Fuel valve must be in ON position</li> <li>4) Choke level must be in CLOSE position for a cold start</li> <li>5) Clean fuel line</li> <li>6) Clean, adjust gap, or replace</li> <li>7) Wait a few minutes to restart, but do not prime</li> </ol> |
| Engine runs erratically  | <ol style="list-style-type: none"> <li>1) Spark plug wire is loose</li> <li>2) Unit running with choke lever in CLOSE position</li> <li>3) Blocked fuel line or stale fuel</li> <li>4) Vent plugged</li> <li>5) Water or dirt in fuel system</li> <li>6) Dirty air cleaner</li> <li>7) Improper carburettor adjustment</li> </ol> | <ol style="list-style-type: none"> <li>1) Connect and tighten spark plug wire</li> <li>2) Move choke lever to OPEN position</li> <li>3) Clean fuel line. Fill tank with clean fresh gasoline</li> <li>4) Clear vent</li> <li>5) Drain fuel tank. Refill with fresh fuel</li> <li>6) Clean or replace air cleaner</li> <li>7) Refer to engine manual</li> </ol>   |
| Engine overheats   | <ol style="list-style-type: none"> <li>1) Engine oil level low</li> <li>2) Dirty air cleaner</li> <li>3) Air flow restricted</li> <li>4) Carburettor not adjusted properly</li> </ol>   | <ol style="list-style-type: none"> <li>1) Fill crankcase with proper oil</li> <li>2) Clean air cleaner</li> <li>3) Remove housing and clean</li> <li>4) Refer to engine manual</li> </ol>  |
| Grinding action seems too slow, cutter wheel stalls, or no material is discharged when engine is running | <ol style="list-style-type: none"> <li>1) Engine speed is too slow causing belt to slip</li> <li>2) Drive belt is loose or damaged</li> <li>3) Blades are dull or damaged</li> <li>4) Cutter wheel is jammed by debris</li> </ol>   | <ol style="list-style-type: none"> <li>1) Run the engine at full throttle</li> <li>2) Tighten or replace drive belt</li> <li>3) Sharpen or replace knives</li> <li>4) Remove any built-up debris and turn cutter wheel</li> </ol>  |
| The belt frays or rolls over the pulley  | <ol style="list-style-type: none"> <li>1) Rotor drive pulley groove may be nicked</li> <li>2) Drive belts may be stretched</li> <li>3) Pulleys may be misaligned</li> </ol>   | <ol style="list-style-type: none"> <li>1) Check drive belts for wear and hard spots. File off any nicks on the pulley</li> <li>2) Replace drive belts</li> <li>3) Adjust pulleys</li> </ol>  |
| When grinding, branch seems to vibrate and move about excessively with unusual noise                     | <ol style="list-style-type: none"> <li>1) Blades are dull or damaged</li> <li>2) Rotor is overloaded with material</li> </ol>   | <ol style="list-style-type: none"> <li>1) Sharpen or replace blades</li> <li>2) Allow unit to clear itself before grinding again</li> </ol>  |
| The machine's wheels track left or right while being towed   | <ol style="list-style-type: none"> <li>1) Low tire pressure</li> </ol>  | <ol style="list-style-type: none"> <li>1) Add air to tires</li> </ol>  |

# SPARE PARTS REPLACEMENT

## BELTS REPLACEMENT



Before performing any maintenance procedure or inspection, stop the engine, wait at least five minutes to allow all parts to cool. Disconnect the spark plug wire, keeping it away from the spark plug.

**Step 1** Remove the drive belt guard bolts (4 pcs).



**Step 2** Check the belt tension. Belt tension is proper when a 2.27kg to 3.18kg force will deflect the belt 2/5" (10 mm) at the midpoint.

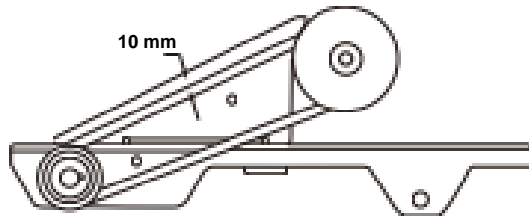

**Step 3** If the belt tension needs to be adjusted, release the engine mounting bolts on both sides (4 pcs.), but do not remove them.

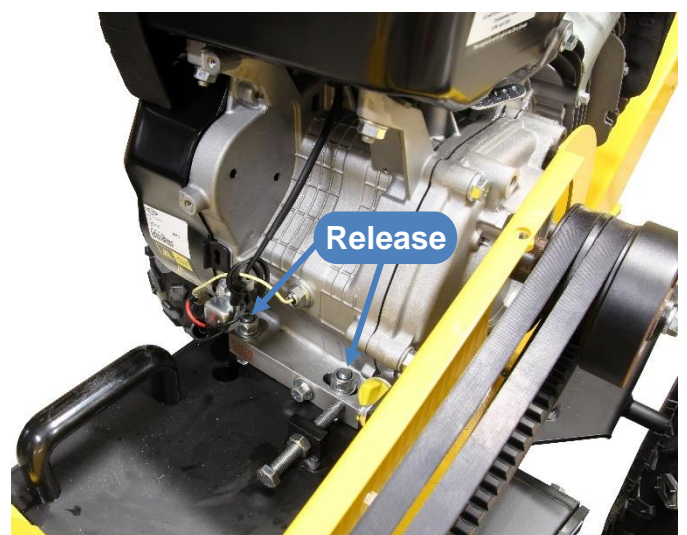
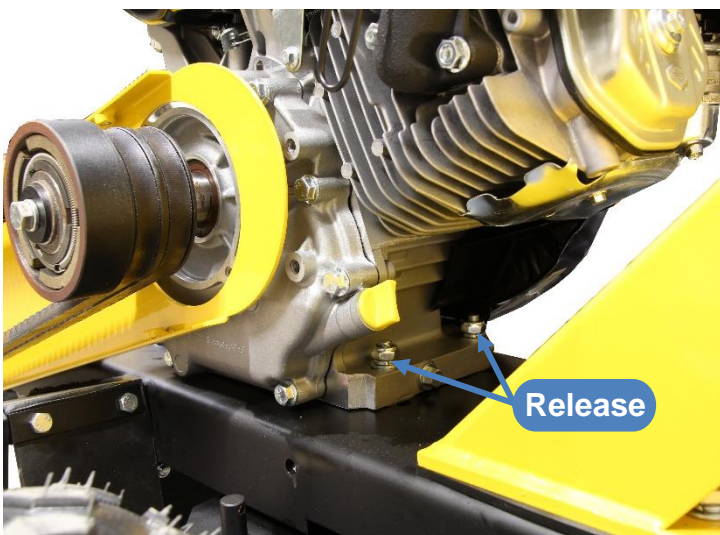

#### Step 4

Release the locknut. To adjust the belts tension, turn tensioner bolt clockwise to increase it or counterclockwise to decrease it.

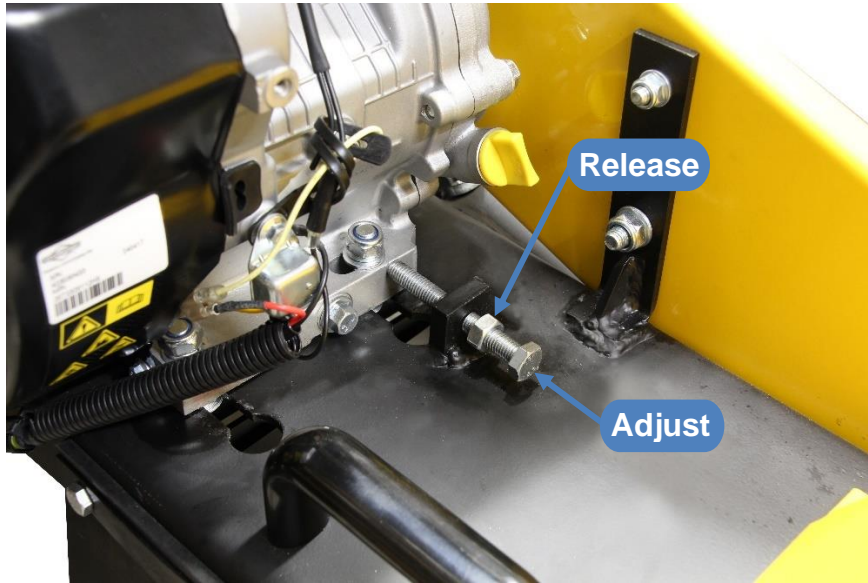

#### Step 5

Skip this point if the correct tension is reached. If tension cannot be achieved, it is necessary to replace the drive belts. To do this, loosen the belt tensioner bolt as loose as possible to remove worn belts. Replace them with new ones by turning the belts one by one onto the pulleys. Then adjust the belt tensioner bolt to achieve the correct tension (see previous steps). NB! The drive belts must always be replaced at the same time / in pair!



#### Step 6

Tighten the tensioner bolt locknut.

#### Step 7

Tighten the engine mounting bolts (4 pcs.).

#### Step 8

Re-install the drive belt guard.

## CLUTCH REPLACEMENT



Before performing any maintenance procedure or inspection, stop the engine, wait at least five minutes to allow all parts to cool. Disconnect the spark plug wire, keeping it away from the spark plug.

### Step 1

Remove the drive belt guard and release the engine mounting bolts (see steps 1 and 3 in the "BELTS REPLACEMENT" section).

### Step 2

Release the locknut. Loosen the belt tensioner bolt as loose as possible.

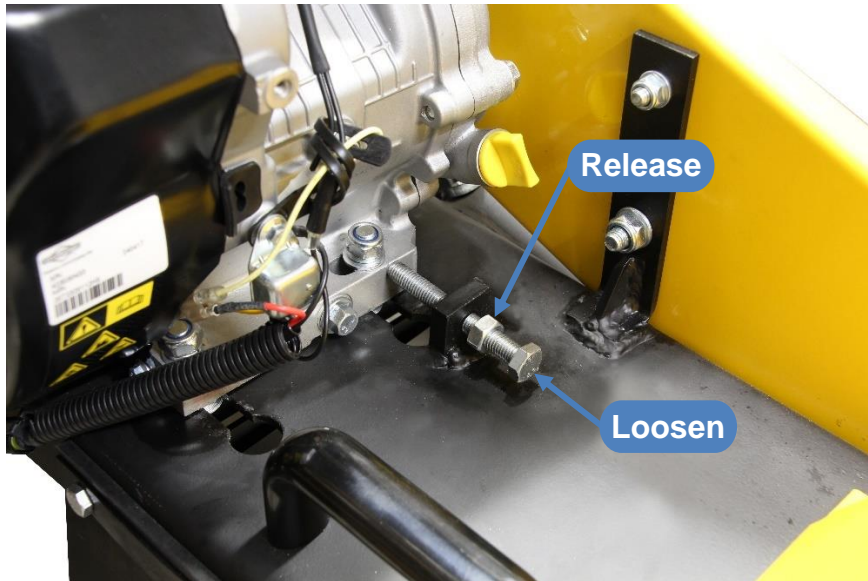

### Step 3

Remove the drive belts.



## Step 4

Remove the clutch bolt together with washers. It is recommended to use an impact wrench.



## Step 5

Remove clutch. Use puller if needed.



## Step 6

Reinstall the spacers (2 pcs.) and key on the engine shaft.

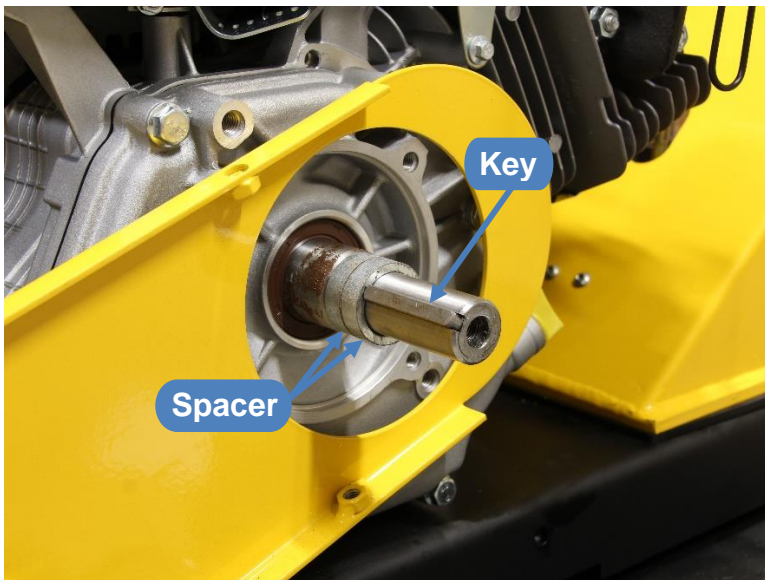

## Step 7

Install a new clutch. Secure the clutch with bolt and washers (5 pcs.)  
**NB! Use thread lock glue on the bolt!**

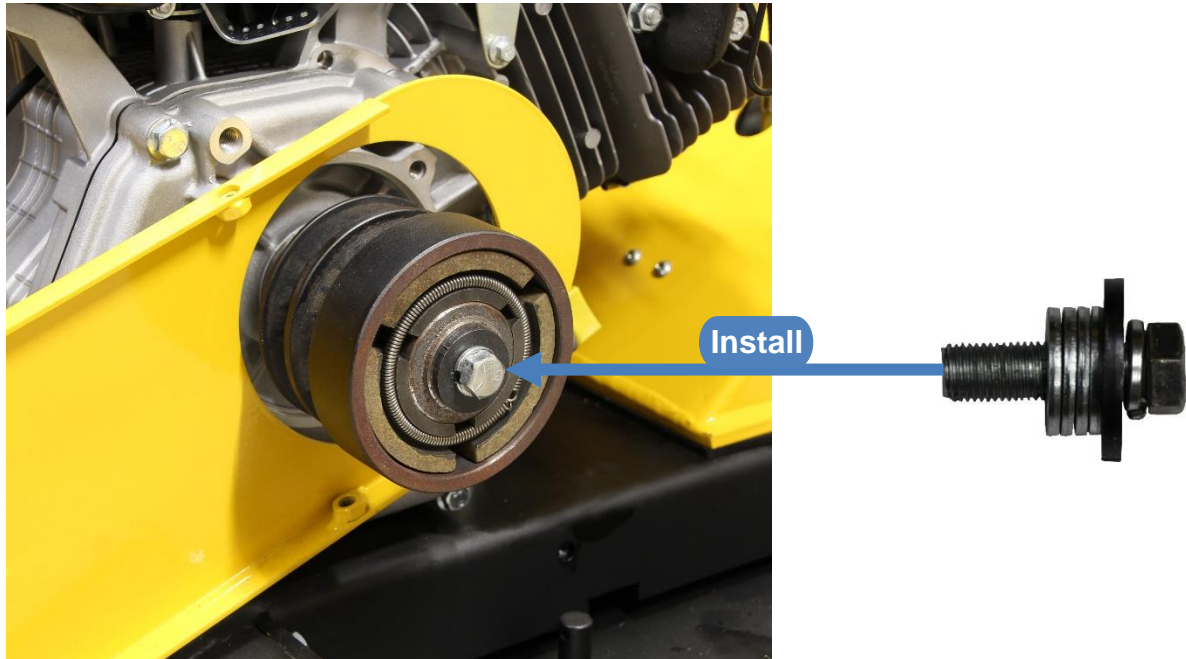

## Step 8

Reinstall or replace the drive belts (see step 5 in the "BELTS REPLACEMENT" section).

## Step 9

Tighten the tensioner bolt locknut.

## Step 10

Tighten the engine mounting bolts (4 pcs.).

## Step 11

Reinstall the drive belt guard.

## TEETH AND HOLDER REPLACEMENT



Before performing any maintenance procedure or inspection, stop the engine, wait at least five minutes to allow all parts to cool. Disconnect the spark plug wire, keeping it away from the spark plug.



When breaking or losing a tooth, it is important to replace it immediately.  
NB! Use only original spare parts



Be careful and wear gloves when working near the teeth.

Among the most critical elements of the stump grinder is the cutting wheel. It is also the most subject to damage and wear. In the course of grinding stumps, it not only makes contact with the wood, but also encounters numerous abrasives and objects in the stump's environment, such as dirt, stones, large rocks and buried scrap.

The loss and wear of cutting teeth can significantly impair the efficiency and performance of the stump grinder. Therefore, it is important to make frequent inspections of the condition of all the cutting teeth and to replace any damaged or worn teeth.

### Step 1

Ensure stump grinder engine has stopped, and the cutting wheel have stopped rotating. Switch off the fuel tap and let the machine cool down. Disconnect the spark plug to ensure the engine cannot be started while changing teeth.

### Step 2

Rotate the cutting wheel using a long wooden stick. Check the condition of the holders and teeth. If only the tooth needs replacement, proceed to step 4. If a holder needs to be replaced, lower the accessory by removing the towbar.

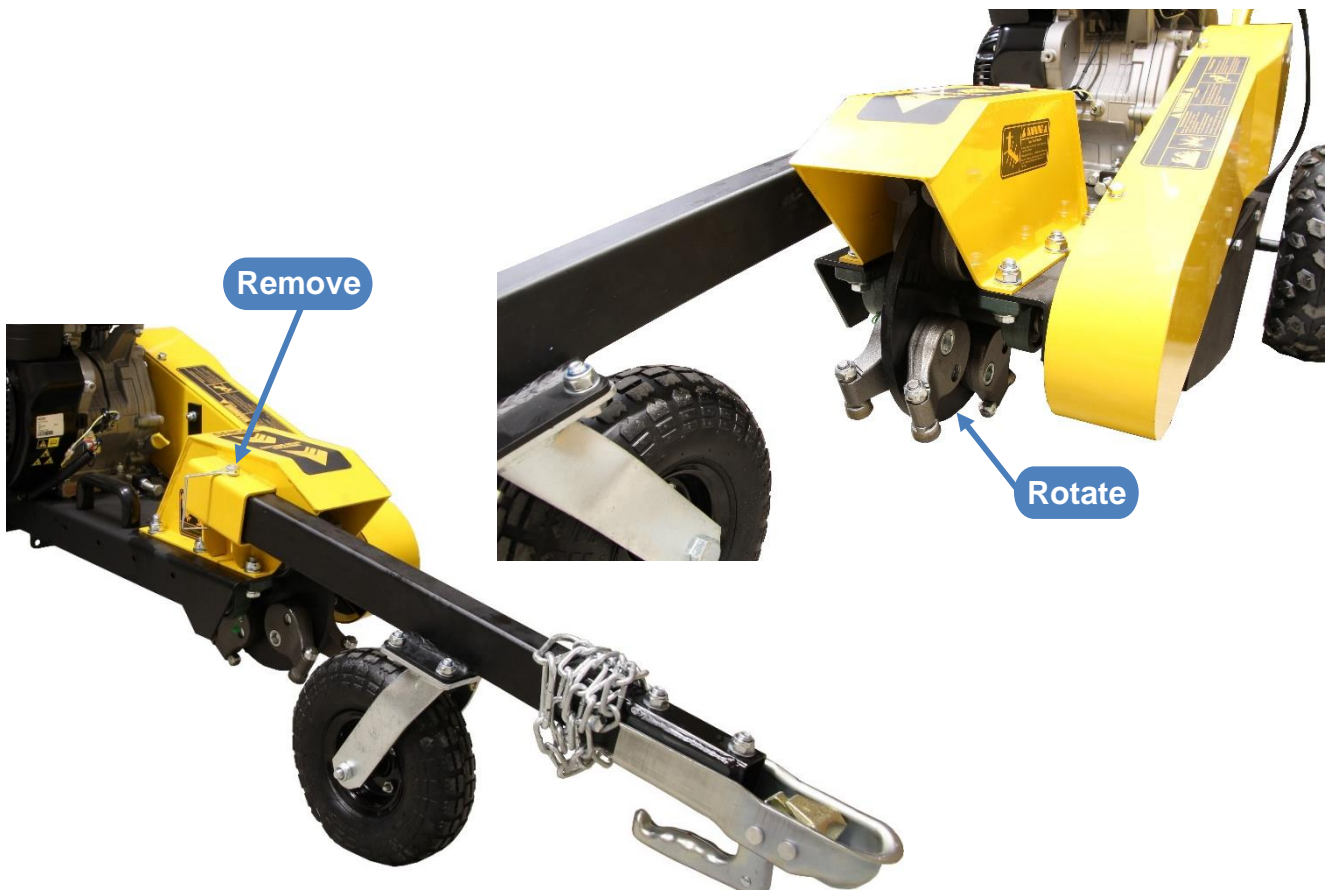

### Step 3

Remove the bolts on both sides of the cutting wheel and replace the holder (note the shape of the holder). Insert the bolts through the cutter wheel into the holder as shown, then tighten them securely.

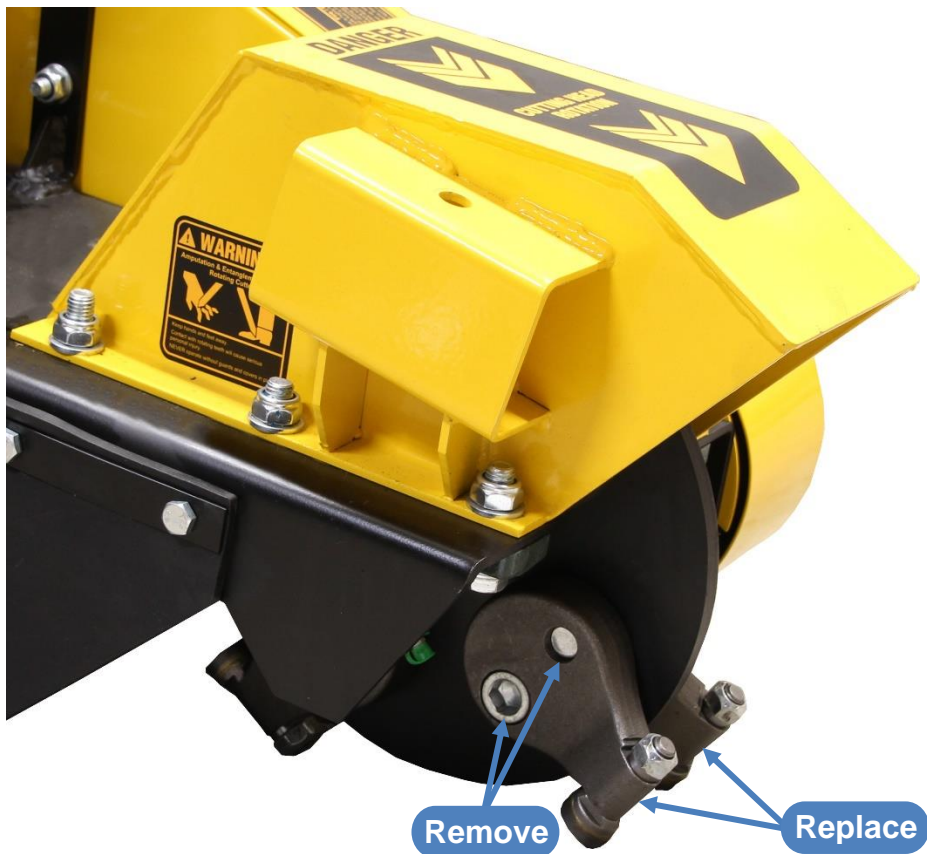

### Step 4

Replace or rotate the tooth by one-third of a turn (note the direction of rotation). Install a new spacer and nut, then tighten the tooth securely to the holder.

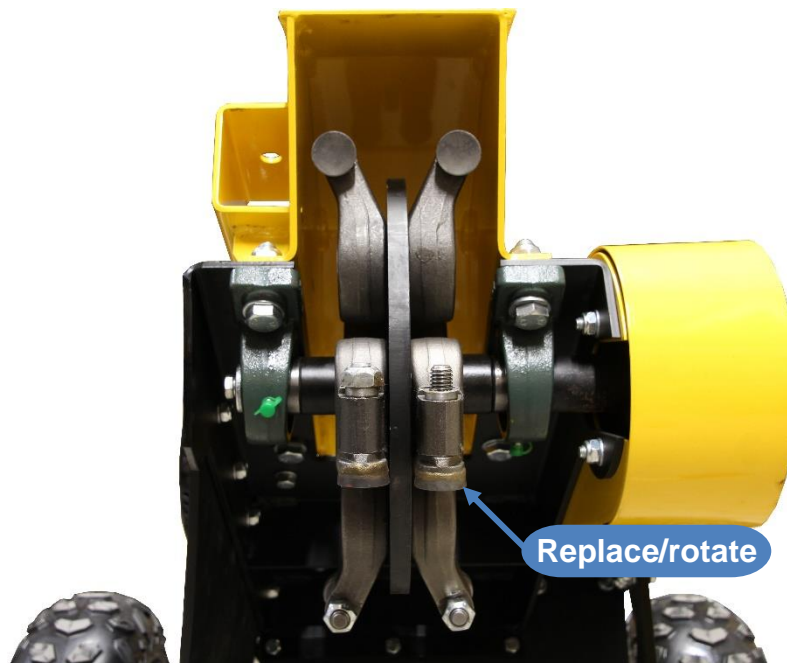

# IRON BALTIC

IRON BALTIC OÜ  
Joa tee 17  
Vääna 76903  
Estonia / Europe

+372 6 533 711  
[sales@ironbaltic.com](mailto:sales@ironbaltic.com)

[www.ironbaltic.com](http://www.ironbaltic.com)  
[www.facebook.com/ironbaltic](https://www.facebook.com/ironbaltic)  
[www.youtube.com/user/ironbalticLtd](https://www.youtube.com/user/ironbalticLtd)

