

# IRON BALTIC

## DRIVE BELT SET (XPZ925)

DOWNLOAD MULTILINGUAL  
USER MANUAL



[code.ironbaltic.com/u/cSG4H4kc](https://code.ironbaltic.com/u/cSG4H4kc)

Code 92.1600

Version 17092024



**Keep this manual for future reference!**

If you need any spare parts, please send this packaging data to your local dealer or to Iron Baltic [sales@ironbaltic.com](mailto:sales@ironbaltic.com)

Iron Baltic Ltd | +372 653 3711 | [sales@ironbaltic.com](mailto:sales@ironbaltic.com) | [www.ironbaltic.com](http://www.ironbaltic.com)

# SPECIFICATION

Pos.	Description	Code	Amount
1	Drive belt (XPZ925)	OT.61.01.030	2

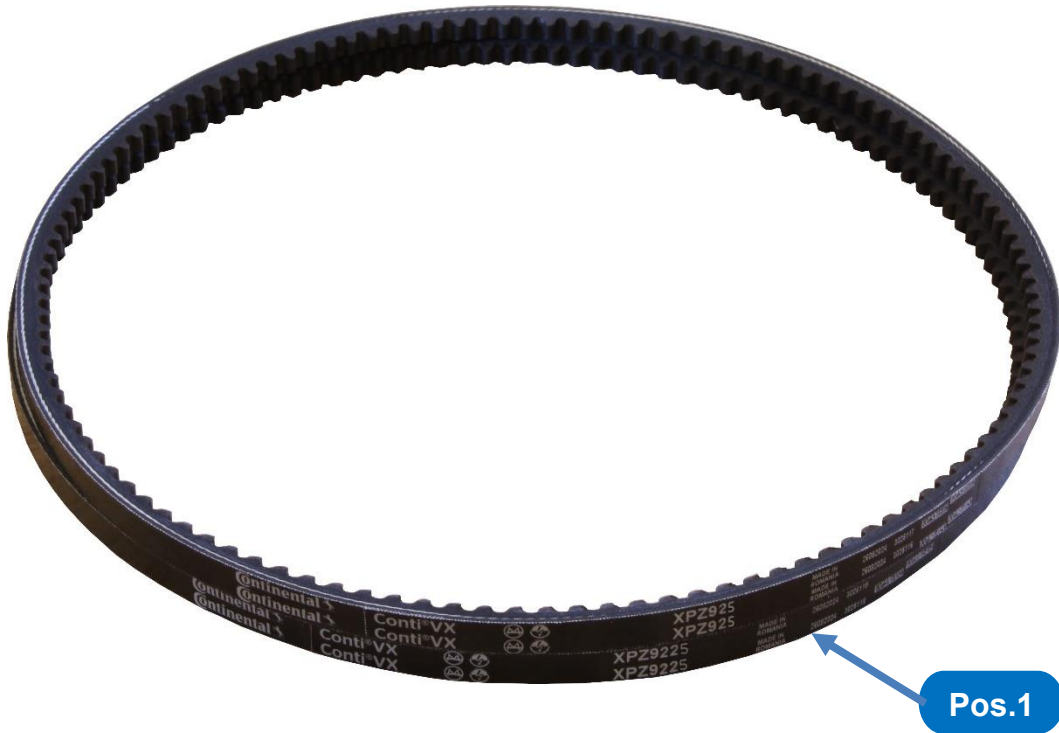

# BELT REPLACEMENT



**BEFORE PERFORMING ANY MAINTENANCE PROCEDURE OR INSPECTION, STOP THE ENGINE, WAIT FIVE MINUTES TO ALLOW ALL PARTS TO COOL. DISCONNECT THE SPARK PLUG WIRE, KEEPING IT AWAY FROM THE SPARK PLUG. PERSONAL PROTECTIVE EQUIPMENT MUST BE USED WHEN REPLACING BELTS!**

**!! Check belts wear and tension regularly. Over- and under-tensioning will cause premature wear of the belts !!**

## Step 1

Loosen the engine holding bolts.

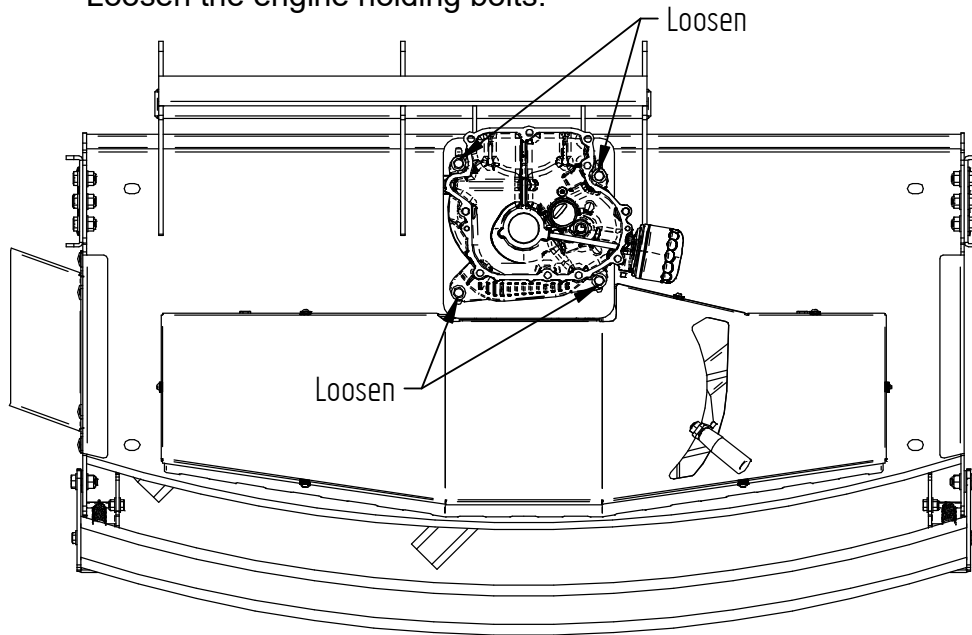

*\* Tube frame and engine components removed for better visibility.*

## Step 2

Remove bolts and belt drive cover.

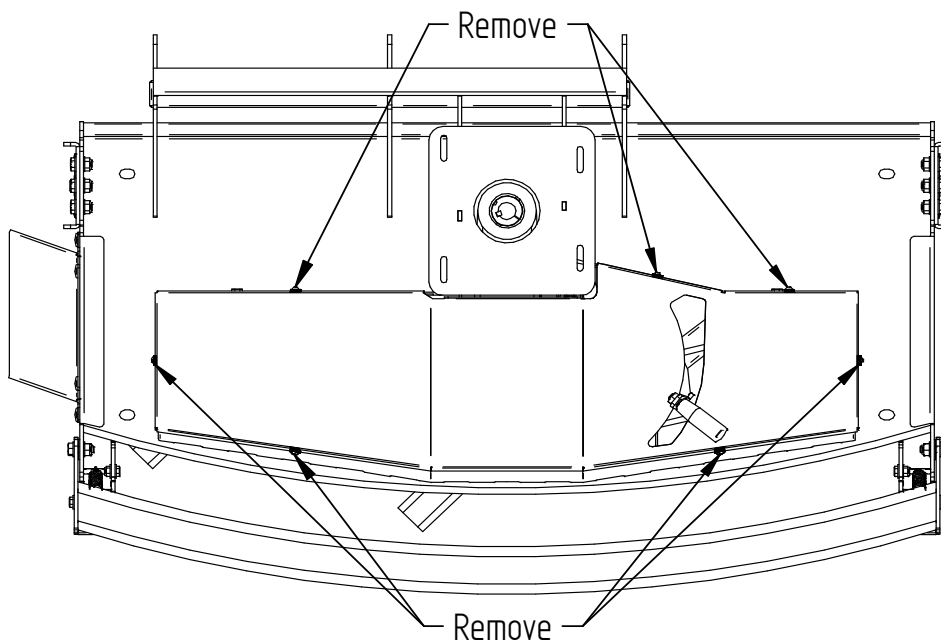

*\* Engine removed for better visibility.*

### Step 3

Loosen the tensioning plate bolts.

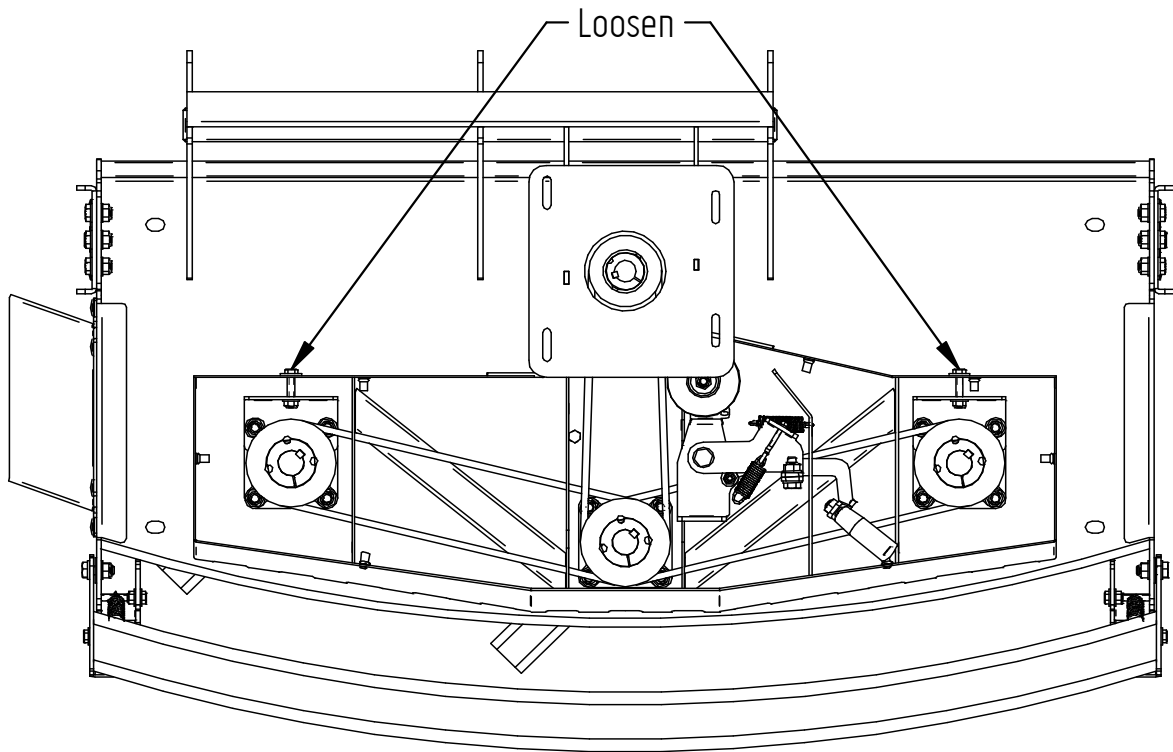

### Step 4

Loosen the bearing housing bolts from both side of the front cutter.

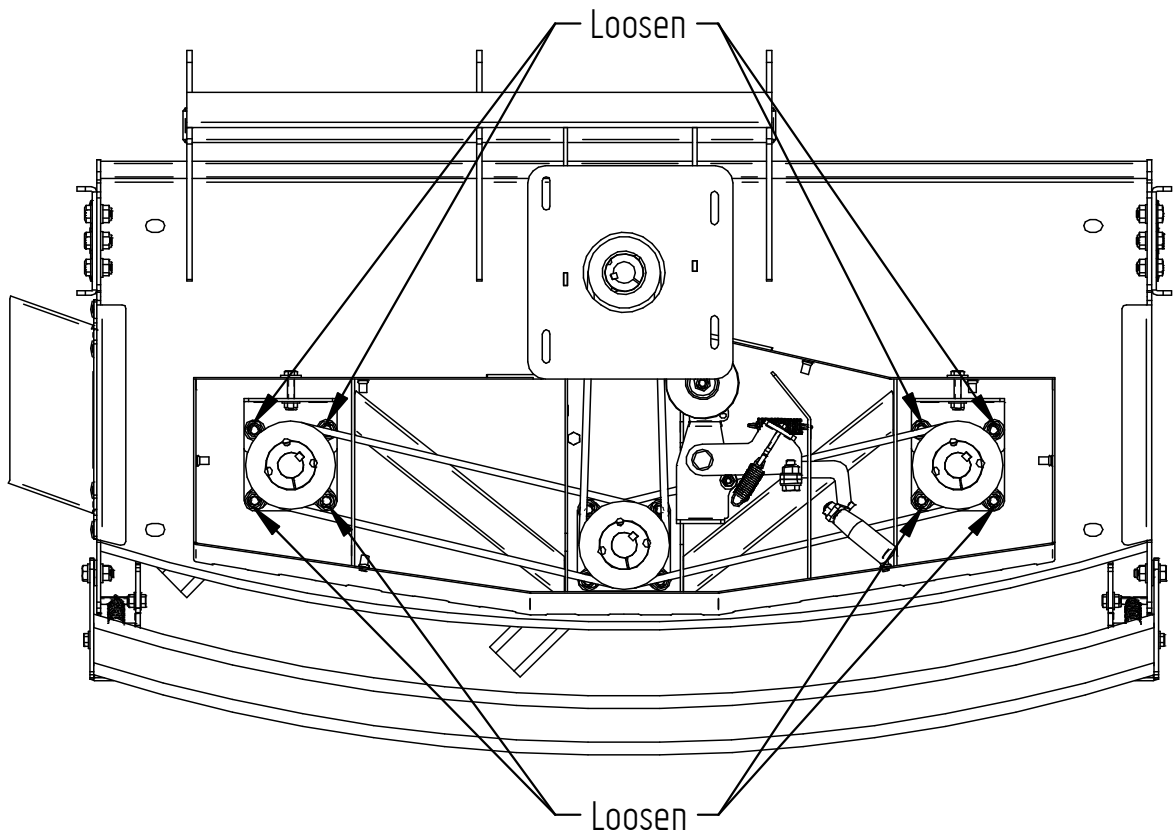

## Step 5

Replace the belts. **NB! On the transmission shafts use XPZ1087 V-belts and from the engine to the transmission shaft use XPZ925 V-belts!**

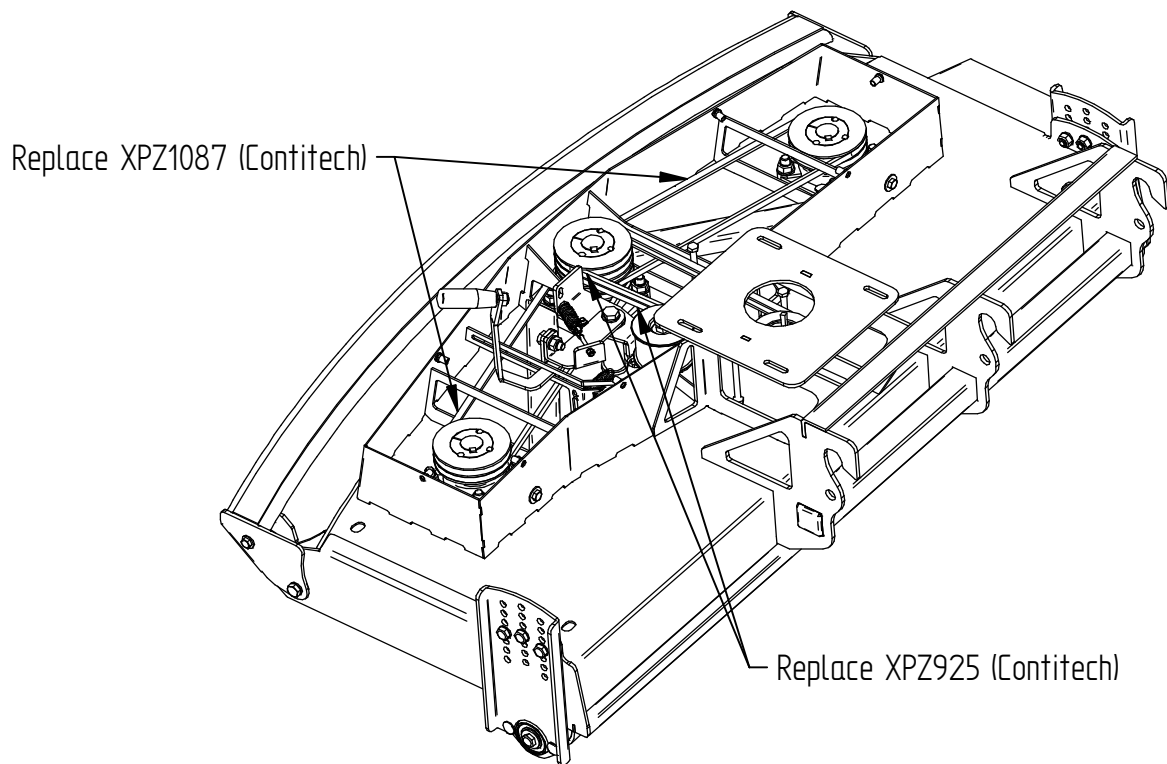

## Step 6

Increase the XPZ1087 belts tension by tightening the bolts until belts tightened up to a position where they still can be compressed 10-15 mm by hand (see next page).

**NB! Make sure that the V-belts are in the correct position on the pulleys!**  
**NB! Check that the belt does not hit any structure.**

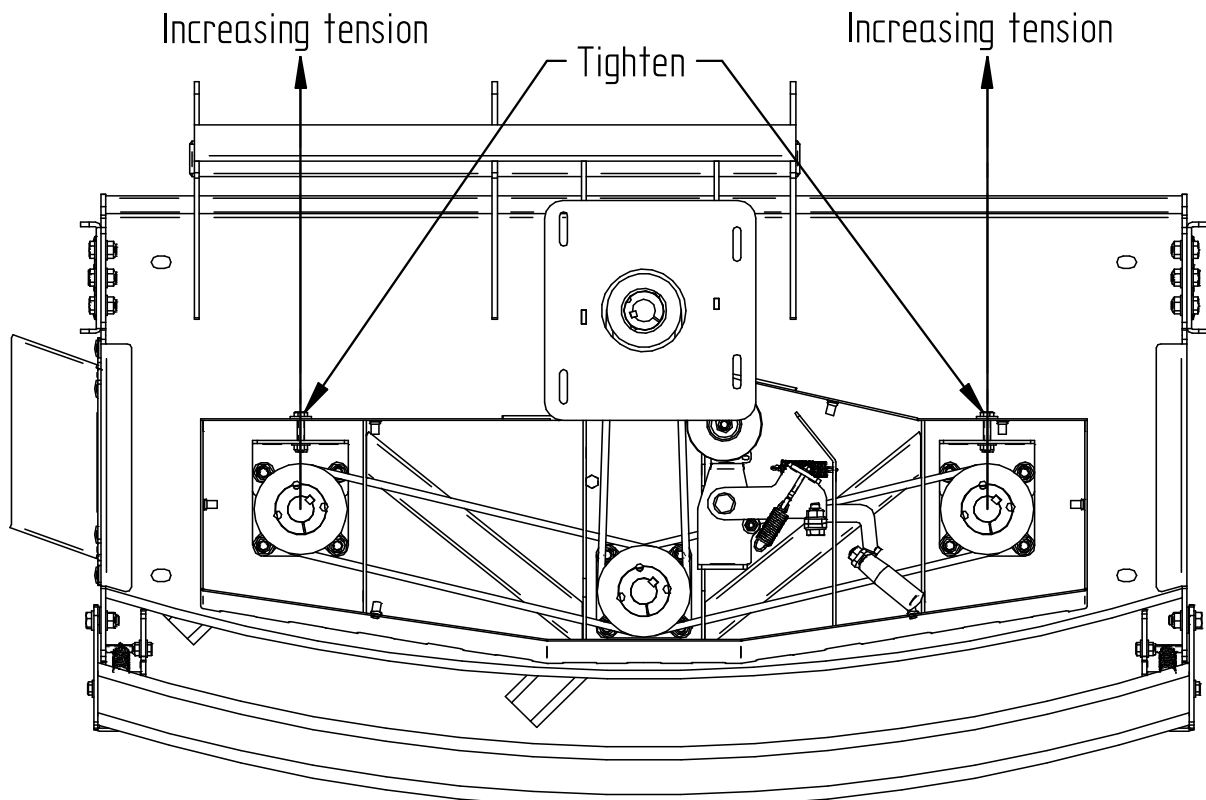

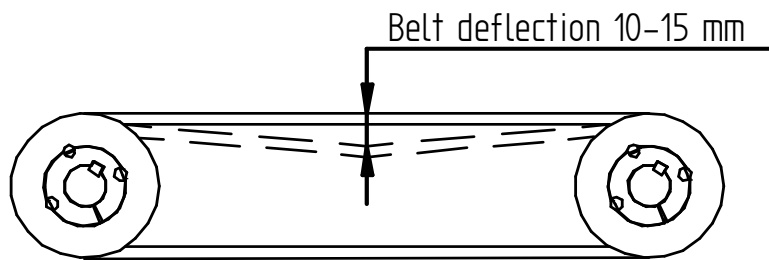

Before tensioning, we recommend to check pulleys alignment to avoid belt wear.

1. Place the metal ruler on top of one pulley so that it is flat and stably positioned.
2. Position the other end of ruler on top of the second pulley and check for any gap between the pulley and the ruler.
3. If the pulleys are correctly aligned at the same height, there should be no significant gap between them.
4. If you notice any gap between one pulley and the other, adjust the height of the pulleys accordingly to ensure both pulleys are evenly installed.

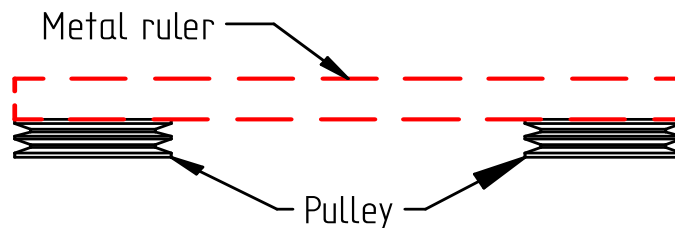

**Attention!**

!! Take care to prevent fingers from being caught between the belt and pulley !!

**Step 7**

Fasten the bearing housing bolts to 90 Nm.

**Step 8**

Increase the XPZ912 V-belts tension by sliding the motor until V-belts tightened up to a position where they still can be compressed 40-50 mm by hand (see next page).

**NB! The clutch must be engaged to the operating position!**

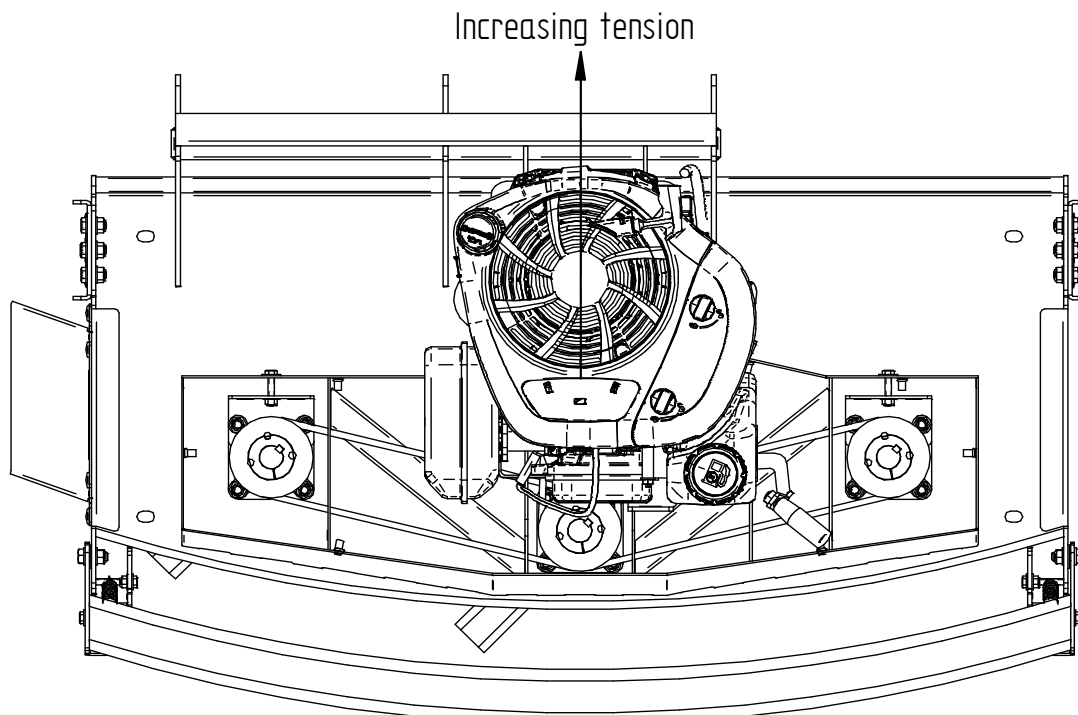

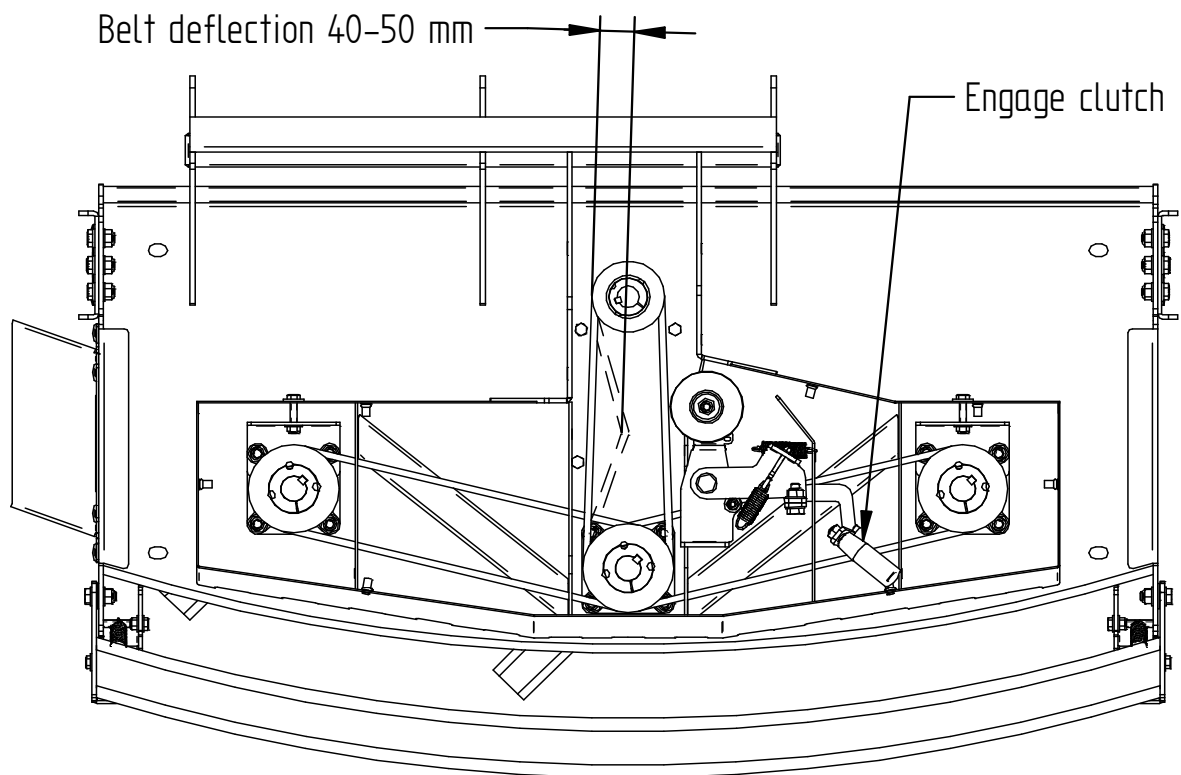

*\* Some components removed for better visibility.*



**Attention!**

!! Take care to prevent fingers from being caught between the belt and idler pulley !!

**Step 9** Fasten the engine holding bolts to 25 Nm.

**Step 10** Re-install belt drive cover and fasten the bolts to 10 Nm.

# IRON BALTIC

IRON BALTIC OÜ  
Joa tee 17  
Vääna 76903  
Estonia / Europe

+372 6 533 711  
[sales@ironbaltic.com](mailto:sales@ironbaltic.com)

[www.ironbaltic.com](http://www.ironbaltic.com)  
[www.facebook.com/ironbaltic](https://www.facebook.com/ironbaltic)  
[www.youtube.com/user/ironbalticLtd](https://www.youtube.com/user/ironbalticLtd)

