

IRON BALTIC

MID-MOUNT ADAPTER

QJMOTOR SFA 600/1000

Code 03.17000

Version 26062025

DOWNLOAD MULTILINGUAL
USER MANUAL



code.ironbaltic.com/u/OnDCplku



Keep this manual for future reference!

If you need any spare parts, please send this packaging data to your local dealer or to Iron Baltic
sales@ironbaltic.com

SPECIFICATION

Pos.	Description	Code	Amount
1	Adapter	03.17001K	1
2	Pin 10x40	14.003	2
3	U-clamp M8x38	14.009	4
4	Cotter pin 2mm DIN 11024	OT.07.01.010	2
5	Bolt M6x25 DIN933	OT.02.02.070	2
6	Washer Ø6/15 SFS3738	OT.04.03.020	2
7	Washer Ø8/20 SFS3738	OT.04.03.030	8
8	Nyloc nut M8 DIN985	OT.03.02.040	8

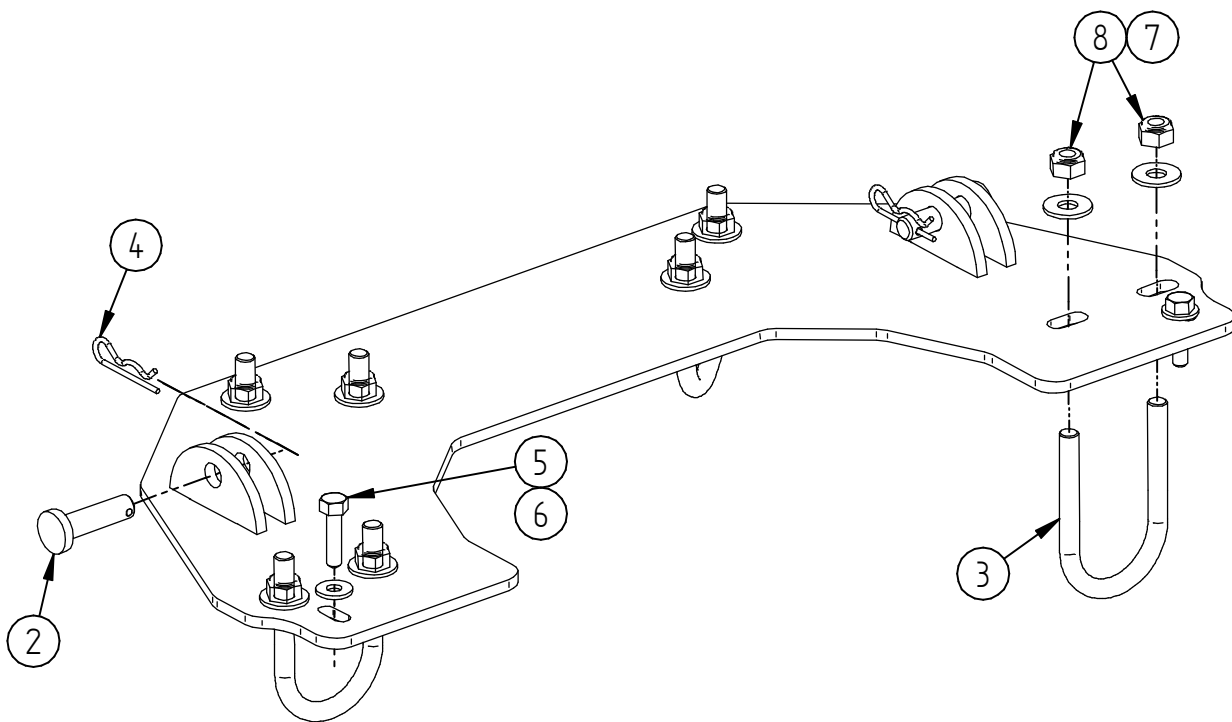

Numbers on drawing correspond to Pos numbers on specification table.



TOOLS REQUIRED FOR INSTALLATION:

- Socket wrench 10mm
- Socket wrench 13mm



NB!

Designing the adapter, original/factory tires were taken into consideration!

QJMOTOR SFA 600 front: 25x8.00-12 and rear: 25x10.00-12.

QJMOTOR SFA 1000 front: 27x9.00-14 and rear: 27x11.00-14.

FITTING INSTRUCTION WITHOUT / ORIGINAL SKID PLATE

Step 1

Remove original front and middle plastic. If you want to use the adapter with original plastic skid plate, make cut-outs for the U-clamps.

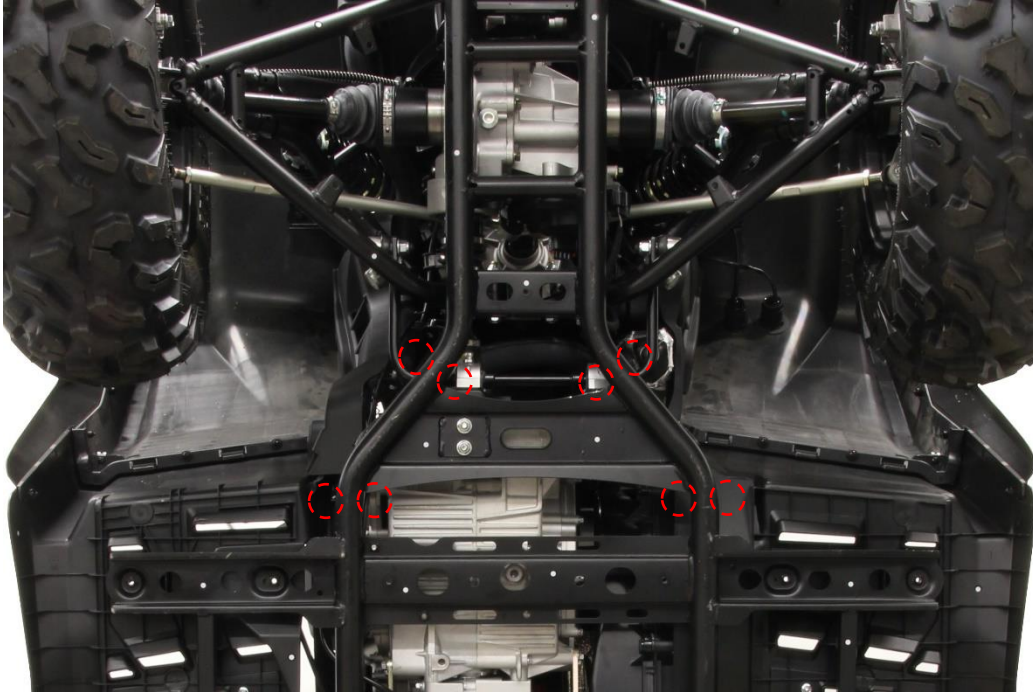

Step 2

Install adapter (Pos.1). For fastening use U-clamps (Pos.3), Ø8/20 washers (Pos.7) and M8 nylock nuts (Pos.8).

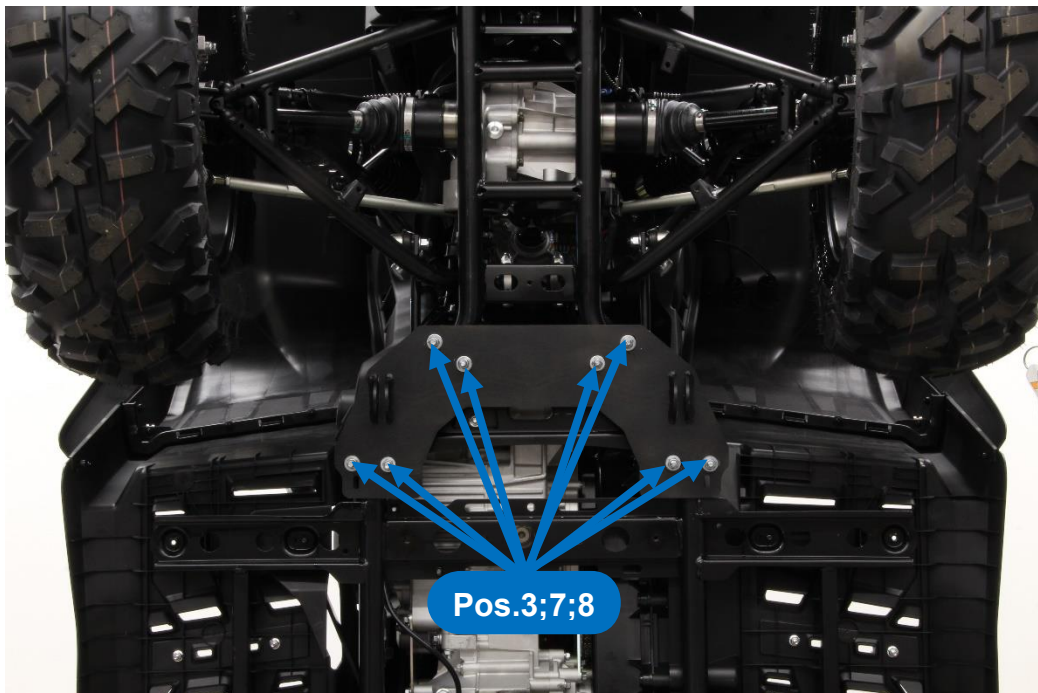

Step 3

Install pins (Pos.2) to the adapter. Use cotter pins (Pos.4) to fix the pins.

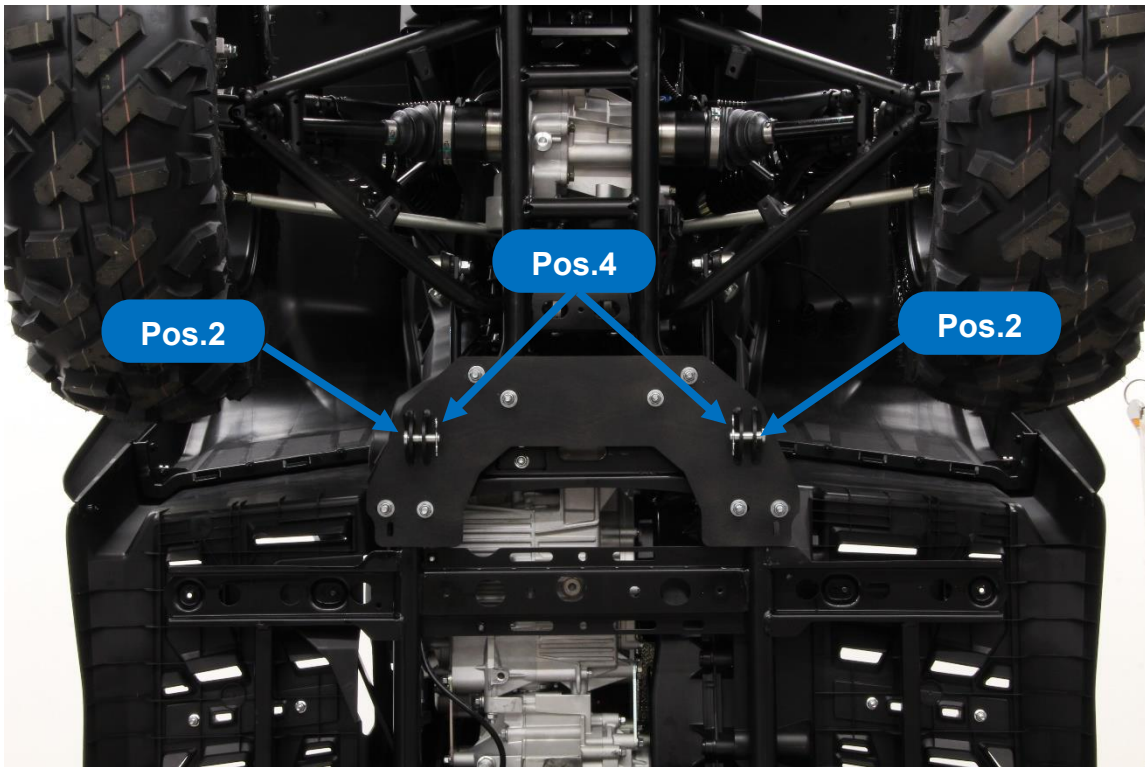

FITTING INSTRUCTIONS WITH IRON BALTIC SKID PLATE

Step 1 Remove skid plate left and right side protection.

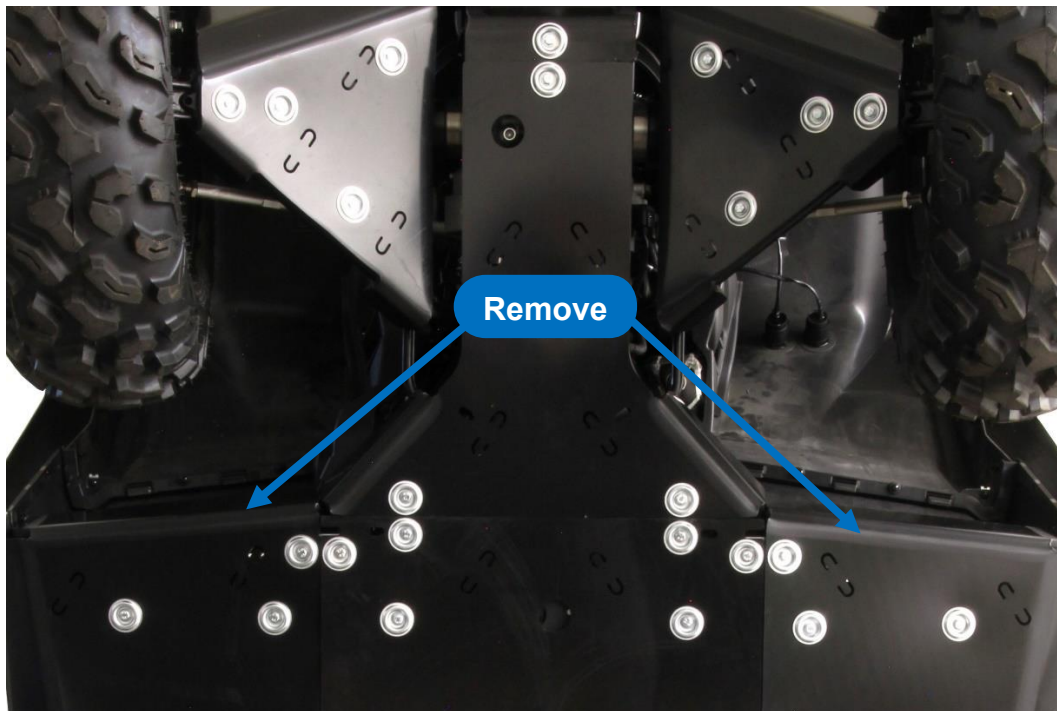

Step 2 Remove bolts and connecting plates as shown in the picture.

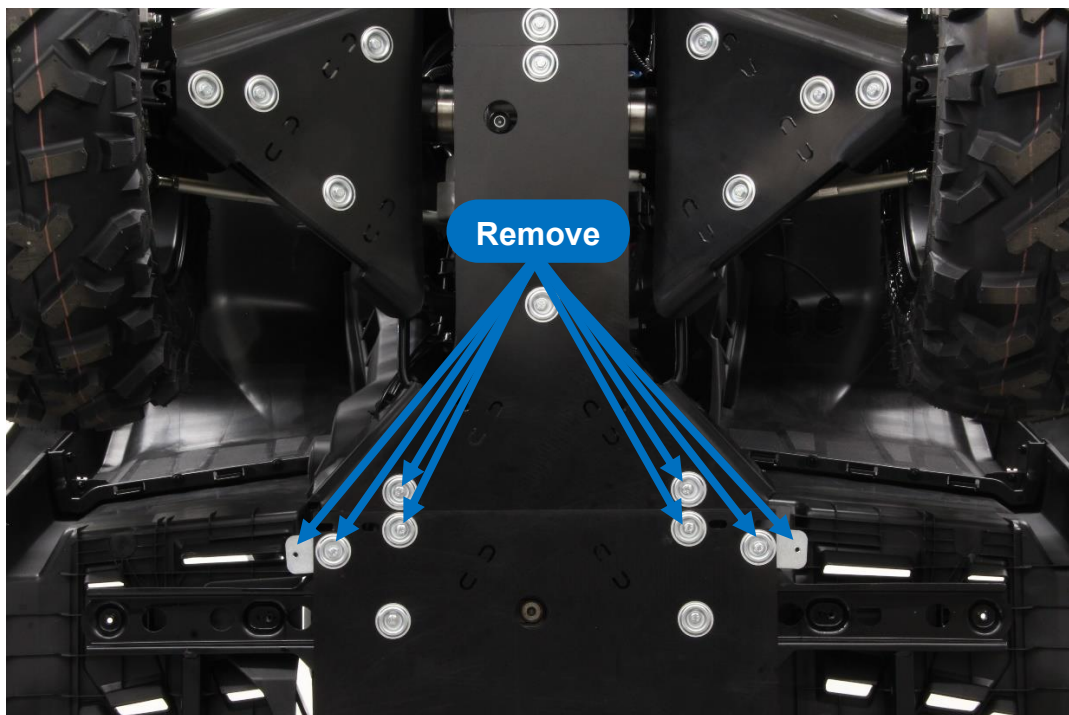

Step 3

Install adapter (Pos.1). For fastening use U-clamps (Pos.3), Ø8/20 washers (Pos.7) and M8 nylock nuts (Pos.8).

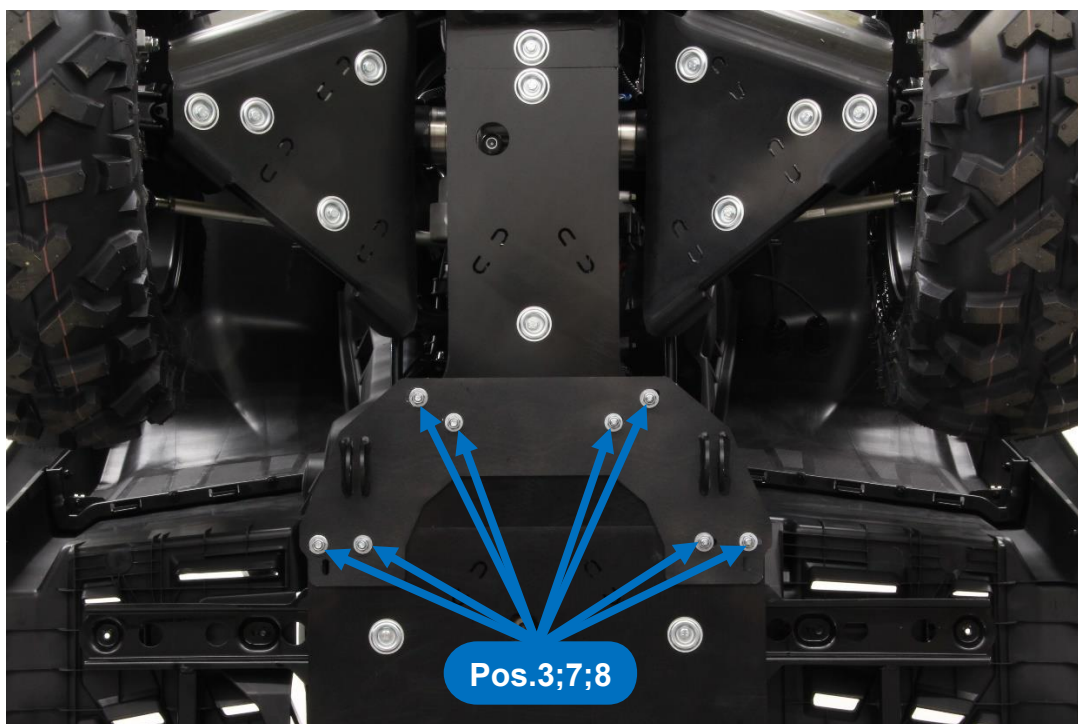

Step 4

Install connecting plates to the adapter. For fastening use M6x25 bolts (Pos.5) and Ø6/15 washers (Pos.6).

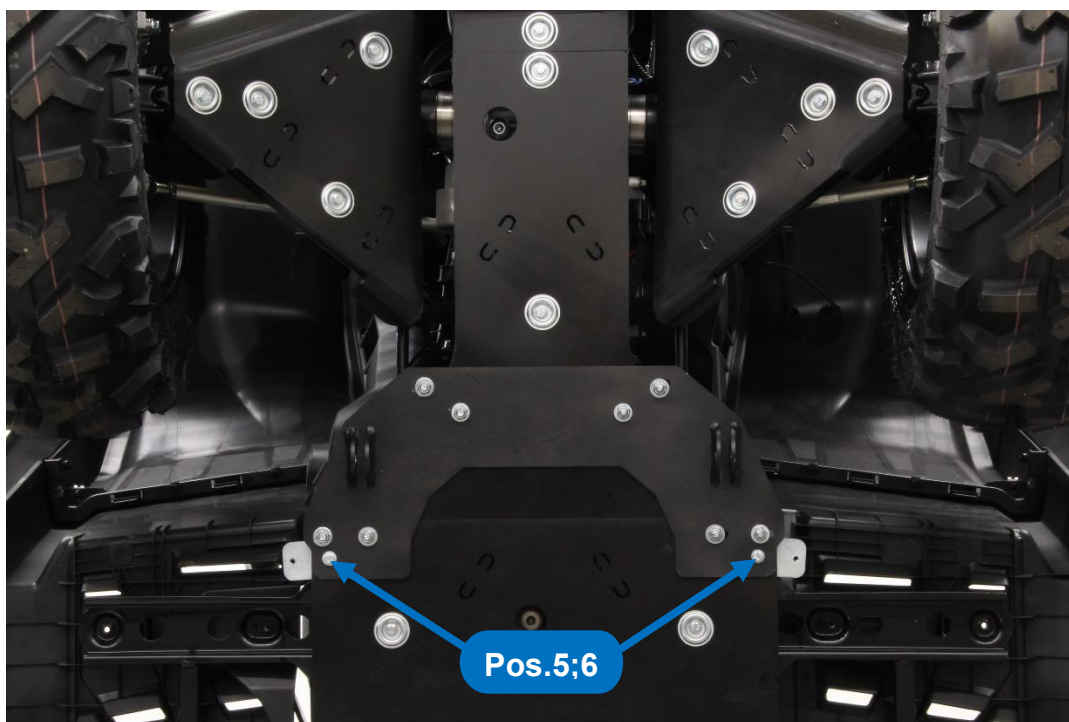

Step 5 Install pins (Pos.2) to the adapter. Use cotter pins (Pos.4) to fix the pins.

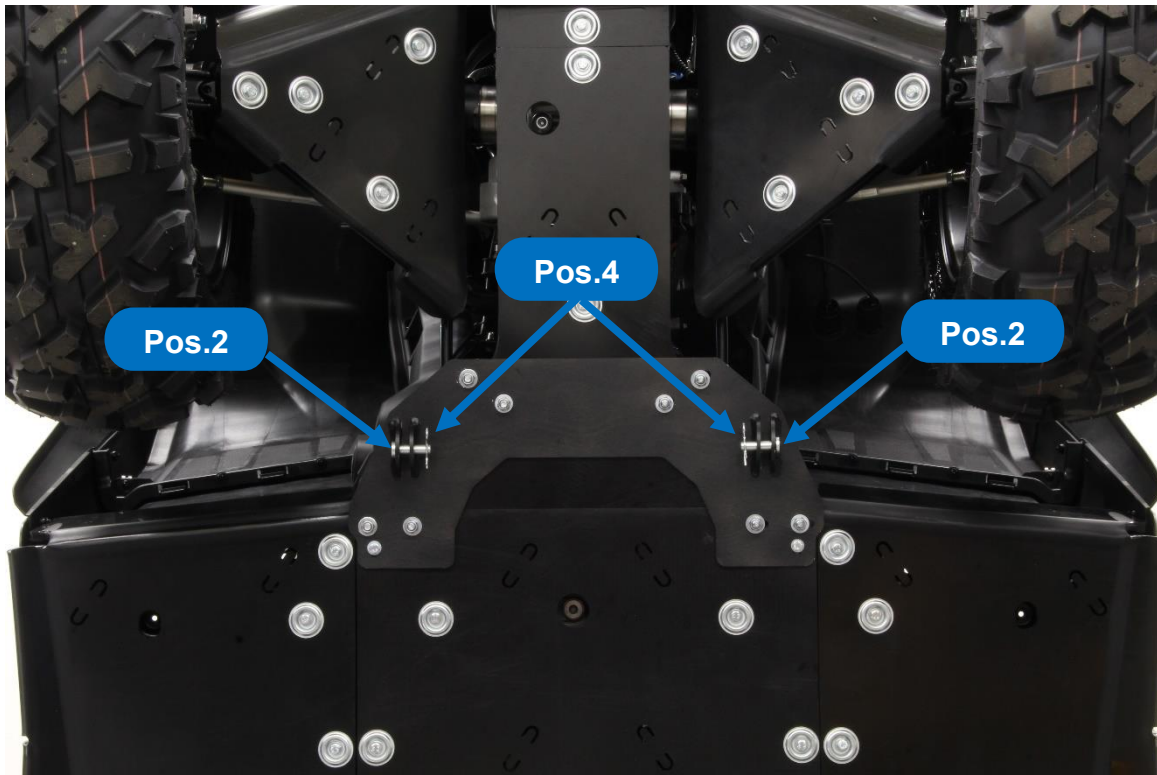

IRON BALTIC

IRON BALTIC OÜ
Joa tee 17
Vääna 76903
Estonia / Europe

+372 6 533 711
sales@ironbaltic.com

www.ironbaltic.com
www.facebook.com/ironbaltic
www.youtube.com/user/ironbalticLtd

