

VOID

Hear. Feel. Connect.

voidacoustics.com

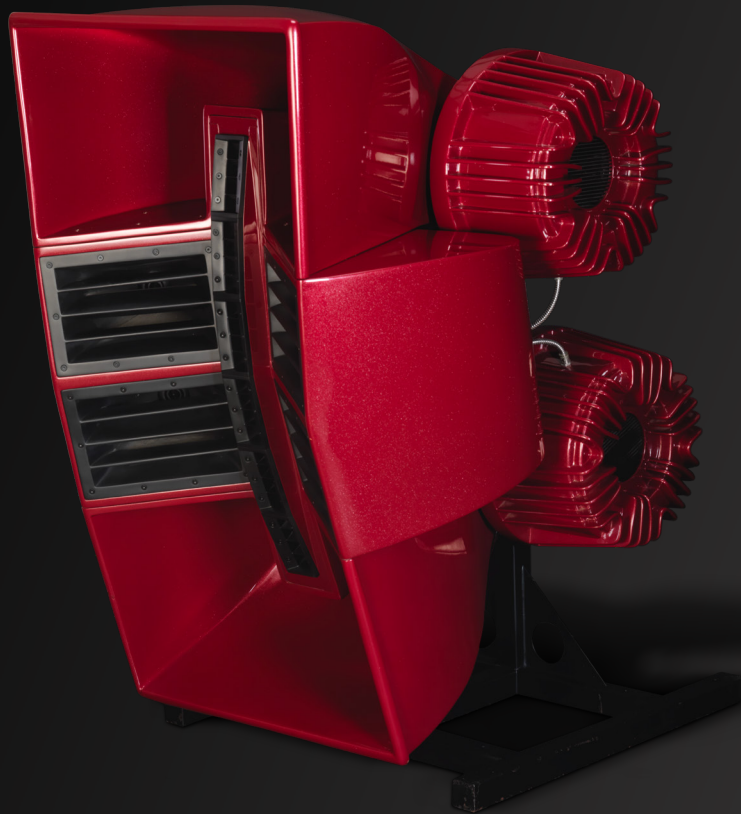

Incubus System

Sonically and visually paralysing

USER GUIDE V2.1

©2023 Void Acoustics Research Ltd.

This user guide is subject to change without notice.
For the latest online version, visit: www.voidacoustics.com

Void Acoustics and the Void logo are registered trademarks of Void Acoustics Research Ltd. in the United Kingdom, USA and other countries; all other Void trademarks are the property of Void Acoustics Research Ltd.

Contents

1	Safety and Regulations	4	5.10	Incubus Sub Wiring Diagram	19
1.1	Important Safety Instructions	4	5.11	Incubus Sub Bias Q5 speakON™ wiring	20
1.2	Limitations	4			
1.3	EC Declaration of Conformity	4			
1.4	UKCA Conformity	4	6	Mounting	21
1.5	Warranty Statement	4	6.1	Installation Safety	21
1.6	WEEE Directive	4	6.2	Ground Stack Bracket	22
2	Unpacking and Checking	5	7	Adjustments	24
			7.1	Wheel Removal	24
3	About	6	7.2	Hyperfold Grille Removal	25
3.1	Welcome	6			
3.2	Incubus Series Overview	6	8	Service	26
			8.1	Return Authorisation	26
4	Specifications and Dimensions	7	8.2	Shipping and Packing Considerations	26
4.1	Air Array	7			
4.1.1	Key Features	7	9	Appendix	27
4.1.2	Air Array Specifications	7			
4.1.3	Air Array Dimensions	8			
4.2	Hyperfold	9			
4.2.1	Key Features	9			
4.2.2	Hyperfold Specifications	9			
4.2.3	Hyperfold Dimensions	10			
4.2.4	Hyperfold Impedance Graph	10			
4.3	Incubus Sub	11			
4.3.1	Key Features	11			
4.3.2	Incubus Sub Specifications	11			
4.3.3	Incubus Sub Dimensions	12			
4.3.4	Incubus Sub Impedance Graph	12			
5	Cable and Wiring	13			
5.1	Electrical Safety	13			
5.2	Cable Considerations for Fixed Installations	13			
5.3	Typical Amplifier Rack Array	13			
5.4	Air Array Layout	14			
5.5	Air Array Wiring Diagram	15			
5.6	Air Array LF Bias Q5 speakON™ A wiring	16			
5.7	Air Array MHF Bias Q5 speakON™ B wiring	17			
5.8	Hyperfold Wiring Diagram	18			
5.9	Hyperfold Bias Q5 speakON™ wiring	18			

1 Safety and Regulations

1.1 Important safety instructions



The lightning flash with an arrowhead symbol within an equilateral triangle is intended to alert the user to the presence of uninsulated "dangerous voltage" within the product's enclosure that may be of sufficient magnitude to constitute a risk of electric shock to persons.



The exclamation point within an equilateral triangle is intended to alert the user of the presence of important operating and maintenance (servicing) instructions in the literature accompanying the appliance.

Safety instructions - read this first

1. Read these instructions.
2. Keep these instructions.
3. Heed all warnings.
4. Follow all instructions.
5. Do not use this apparatus near water.
6. Clean only with a dry cloth.
7. Do not block any ventilation openings. Install in accordance with the manufacturer's instructions.
8. Do not install near any heat source such as radiators, heat registers, stoves, or other such apparatus that produce heat.
9. Do not defeat the safety purpose of the grounding-type plug. A grounding type plug has two blades and a third grounding prong. The third prong is provided for your safety. If the provided plug does not fit into your outlet, consult an electrician for replacement of the obsolete outlet.
10. Protect power cords from being walked on or pinched particularly at plugs, convenience receptacles, and the point where they exit the apparatus.
11. Only use attachments and accessories specified by Void Acoustics.
12. Only use with the cart, stand, tripod, bracket, or table specified by the manufacturer, or sold with the apparatus. When a cart is used, use caution when moving the cart/apparatus combination to avoid injury from tip-over.
13. Unplug the apparatus during lightning storms or when unused for long periods of time.
14. Refer all servicing to qualified service personnel. Servicing is required when the apparatus has been damaged in any way, such as when the power-supply cord or plug is damaged, liquid has been spilled or objects have fallen into the apparatus, the apparatus has been exposed to rain or moisture, does not operate normally, or has been dropped.
15. Since the mains power supply cord attachment plug is used to disconnect the device, the plug should always be easily accessible.
16. Void loudspeakers can produce sound levels capable of causing permanent hearing damage from prolonged exposure. The higher the sound level, the less exposure needed to cause such damage. Avoid prolonged exposure to the high sound levels from the loudspeaker.

1.2 Limitations

This guide is provided to help familiarise the user with the loudspeaker system and its accessories. It is not intended to provide comprehensive electrical, fire, mechanical and noise training and is not a substitute for industry-approved training. Nor does this guide absolve the user of their obligation to comply with all relevant safety legislation and codes of practice. While every care has been taken in creating this guide, safety is user-dependent and Void Acoustics Research Ltd cannot guarantee complete safety whenever the system is rigged and operated.

1.3 EC declaration of conformity

For EC Declaration of Conformity please go to:

www.voidacoustics.com/eu-declaration-loudspeakers

1.4 UKCA marking

For details of the UKCA marking go to:

www.voidacoustics.com/uk-declaration-loudspeakers

1.5 Warranty statement

For warranty statement go to:

<https://voidacoustics.com/terms-conditions/>

1.6 WEEE directive

If the time arises to throw away your product, please recycle all the components possible.



This symbol indicates that when the end-user wishes to discard this product, it must be sent to separate collection facilities for recovery and recycling. By separating this product from other household-type waste, the volume of waste sent to incinerators or land-fills will be reduced and natural resources will thus be conserved.

The Waste Electrical and Electronic Equipment Directive (WEEE Directive) aims to minimise the impact of electrical and electronic goods on the environment. Void Acoustics Research Ltd complies with the Directive 2002/96/EC and 2003/108/EC of the European Parliament on waste electrical and electronic equipment (WEEE) in order to reduce the amount of WEEE that is being disposed of in land-fill sites. All of our products are marked with the WEEE symbol; this indicates that this product must NOT be disposed of with other waste. Instead it is the user's responsibility to dispose of their waste electrical and electronic equipment by handing it over to an approved reprocessor, or by returning it to Void Acoustics Research Ltd for reprocessing. For more information about where you can send your waste equipment for recycling, please contact Void Acoustics Research Ltd or one of your local distributors.

2 Unpacking and Checking

All Void Acoustics products are carefully manufactured and thoroughly tested before being despatched. Your dealer will ensure that your Void products are in pristine condition before being forwarded to you but mistakes and accidents can happen.

Before signing for your delivery:

- Inspect your shipment for any signs of contamination, abuse or transit damage as soon as you receive it
- Check your Void Acoustics delivery fully against your order
- If your shipment is incomplete or any of its contents are found to be damaged; inform the shipping company and inform your dealer.

Air Array loudspeakers are heavy (144.8 kg/319 lbs including stand) and require a minimum two people to lift.

- Undo the four butterfly catches on the transport case then remove the lid making sure the lid is clear before moving sideways
- If you need to place the Air Array on a flat surface ensure you use a lint free product to protect the finish
- When removing the Air Array take care not to damage the lower tray of the transport case.

Keep the original packaging in case you need to return a product for service later.

See section 1.5 for warranty conditions and see section 8 if your product needs servicing.

3 About

3.1 Welcome

Many thanks for purchasing this Void Acoustics Incubus Series loudspeaker. We truly appreciate your support. At Void, we design, manufacture and distribute advanced professional audio systems for the installed and live sound market sectors. Like all Void products, our highly skilled and experienced engineers have successfully combined pioneering technologies with ground-breaking design aesthetics, to bring you superior sound quality and visual innovation. In buying this product, you are now part of the Void family and we hope using it brings you years of satisfaction. This guide will help you both use this product safely and ensure it performs to its full capability.

3.2 Incubus series overview

Providing levels of control thought impossible and perfect sound quality, the Incubus is the number one choice for club dance systems, owing to its striking physical signature and performance. Hearing the highest quality of unadulterated sound through an Incubus makes it possible to feel as though you are inside music, in a fully immersive aural experience.

4 Specifications and Dimensions

4.1 Air Array

4.1.1 Key features

- Visually striking appearance for style-led environments
- Fibreglass composite construction
- 14 discrete proprietary drive units
- Integrated flying and mounting system
- Ground stack on low frequency enclosures
- Optional floor stand or flying bracket
- Standard red finish, optional custom colours

4.1.2 Air Array specifications

Frequency response	90 Hz - 26 kHz \pm 3 dB
Efficiency ¹	LF: 111 dB 1W/1m, MF: 114 dB 1W/1m, HF: 116 dB 1W/1m
Nominal impedance	LF: 2 x 4 Ω , MF: 2 x 4 Ω , HF: 2 x 5.33 Ω
Power handling ²	LF: 3600 W AES, MF: 800 W AES, HF: 320 W AES
Maximum output ³	146 dB cont, 152 dB peak
Driver configuration	4 x 12" LF, 4 x 3" MF compression driver, 6 x 1" HF compression driver
Dispersion	90°H x 45°V
Connectors	2 x 8-pole speakON™ NL8
Height	1240 mm (48.8")
Width	944 mm (37.2")
Depth	813 mm (32")
Weight	144.8 kg (319.2 lbs) including stand
Enclosure	Fibreglass composite
Rigging	Stack mounted or proprietary flying system
Finish	Smooth cellulose

¹ Measured in half space ² AES2 - 1984 compliant ³ Calculated

4 Specifications and Dimensions

4.1.3 Air Array dimensions

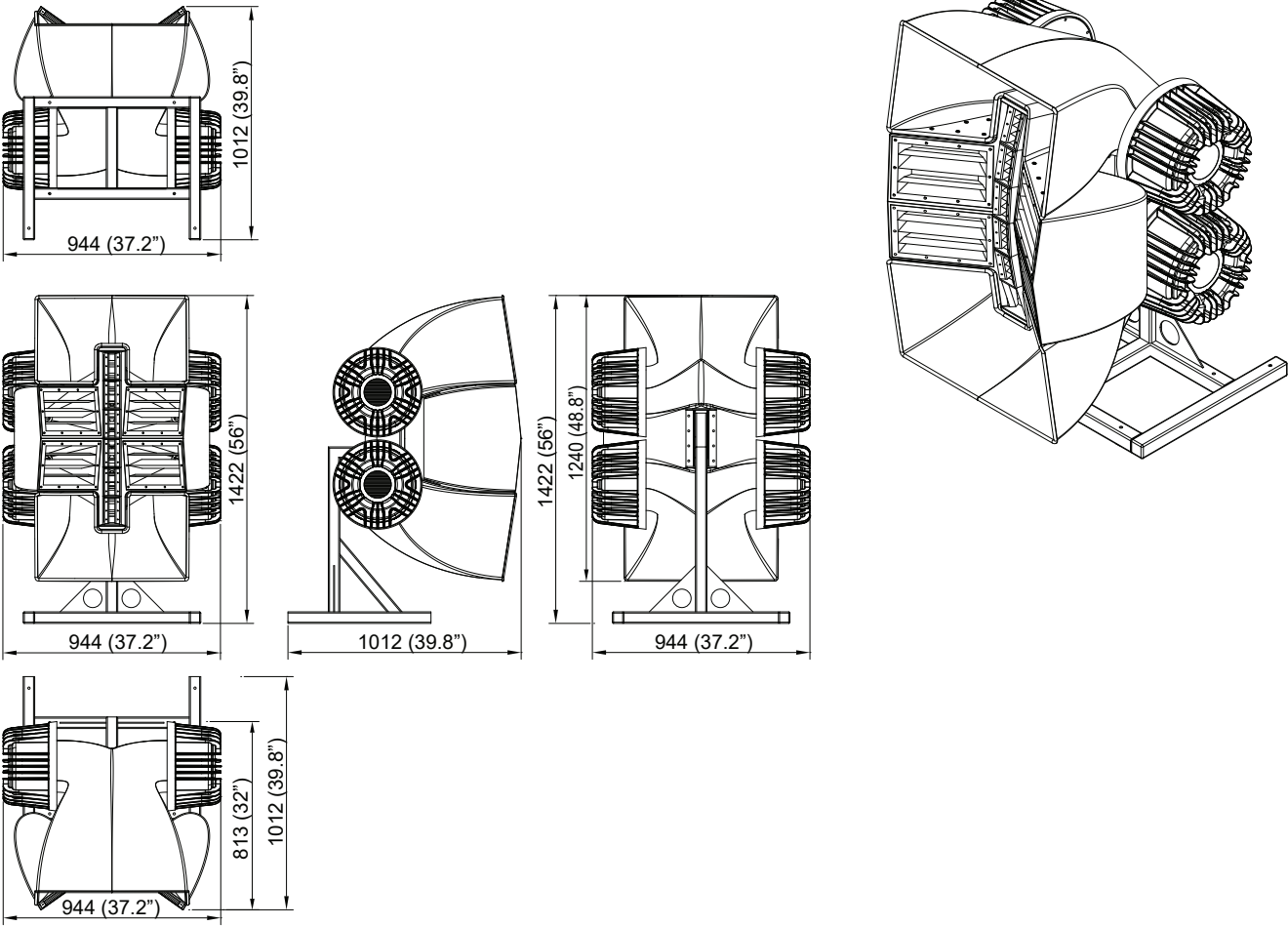

Figure 4.1: Dimensions

4 Specifications and Dimensions

4.2 Hyperfold

4.2.1 Key features

- High power density in a compact footprint
- Exceptional upper bass speed and articulation
- Four high power 15" low frequency drivers
- Distinctive aluminium cabinet bracing
- 18 mm birch plywood construction
- Textured 'TourCoat' polyurea finish

4.2.2 Hyperfold specifications

Frequency response	60 Hz - 190 Hz ± 3 dB
Efficiency ¹	109.5 dB 1W/1m
Crossover points	Preset via dedicated processor
Nominal impedance	2 x 4 Ω
Power handling ²	4000 W AES
Maximum output ³	146 dB cont, 152 dB peak
Configuration	4 x 15" low frequency drivers
Dispersion	Array dependent
Connectors	2 x 4-pole speakON™ NL4
Height	748 mm (29.4")
Width	738 mm (29.1")
Depth	1218 mm (47.9")
Weight	150 kg (330.7 lbs)
Enclosure	18 mm birch plywood
Finish	Textured 'TourCoat' polyurea, smooth cellulose

¹ Measured in half space ² AES2 - 1984 compliant ³ Calculated

4 Specifications and Dimensions

4.2.3 Hyperfold dimensions

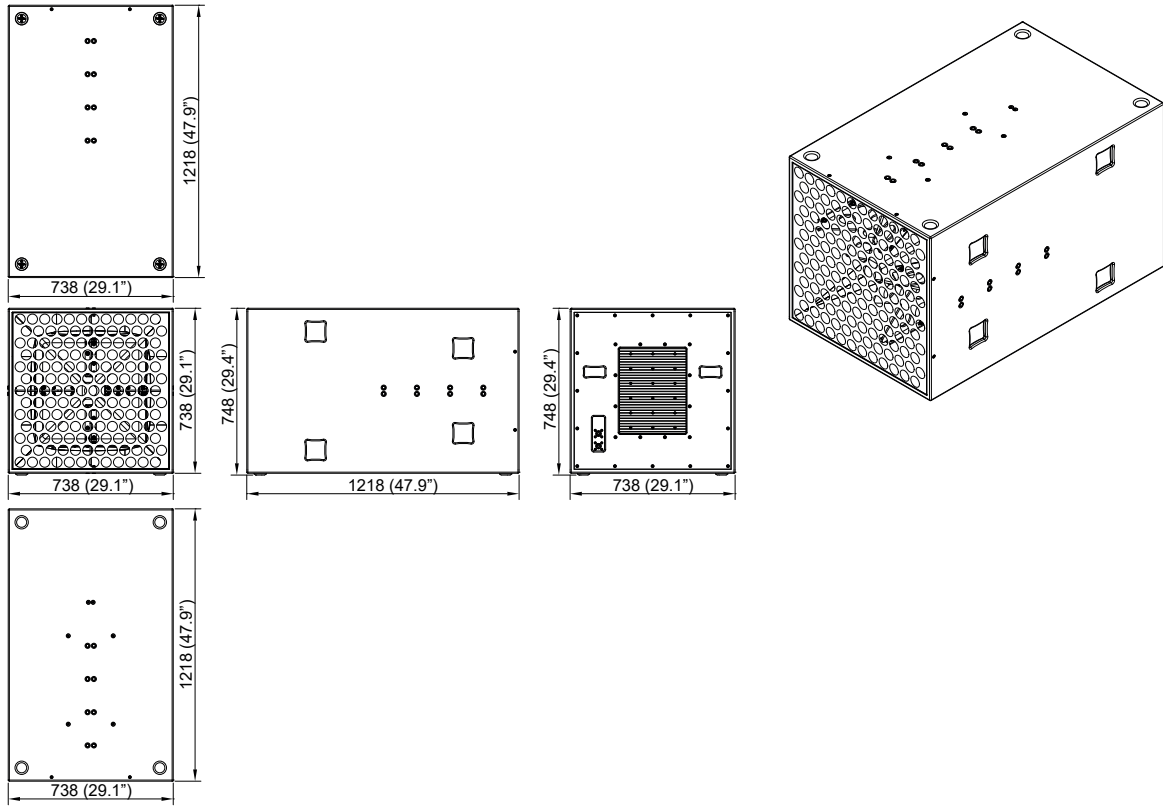

Figure 4.2: Dimensions

4.2.4 Hyperfold impedance graph

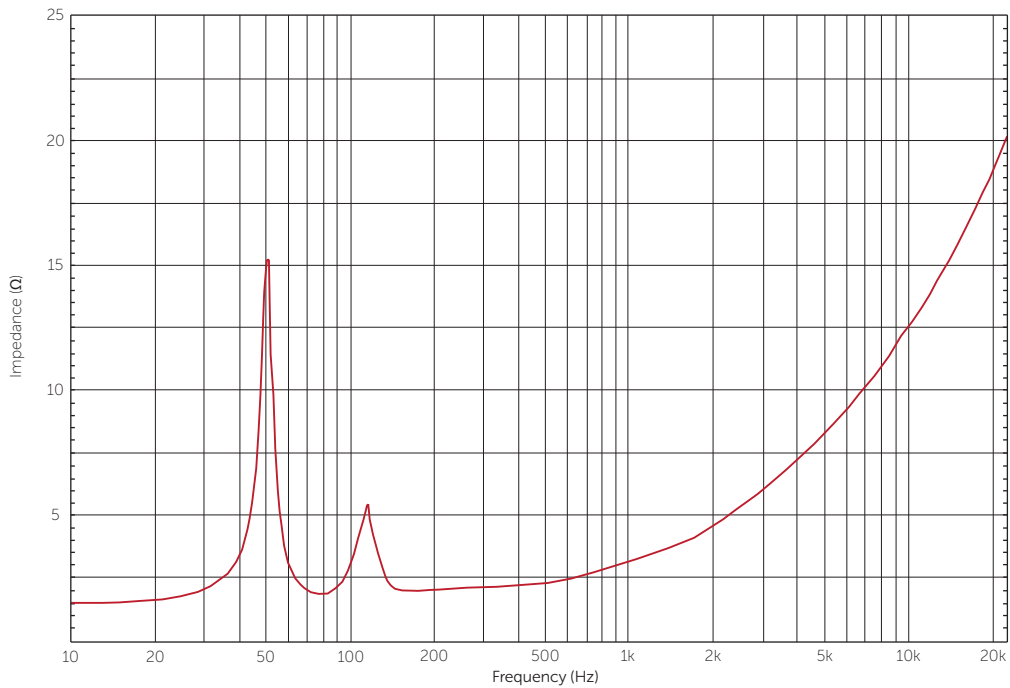

Figure 4.3: Impedance graph

4 Specifications and Dimensions

4.3 Incubus Sub

4.3.1 Key features

- Distinctive aluminium cabinet bracing
- 3 x high power 21" low frequency drivers
- Extended sub frequency response to 30 Hz
- 18 mm birch plywood construction
- Black textured 'TourCoat' polyurea finish

4.3.2 Incubus Sub specifications

Frequency response	29 Hz - 95 Hz \pm 3 dB
Efficiency ¹	105 dB 1W/1m
Crossover point	Preset via dedicated processor
Nominal impedance	3 x 8 Ω
Power Handling ²	6000 W AES
Maximum output ³	142 dB cont, 148 dB peak
Driver configuration	3 x 21" LF with 6" voice coils
Dispersion	Array dependent
Connectors	2 x 8-pole speakON™ NL8
Height	704 mm (27.7")
Width	1479 mm (58.2")
Depth	1218 mm (48")
Weight	214 kg (471.8 lbs)
Enclosure	18 mm birch plywood
Finish	Textured 'TourCoat' polyurea

¹ Measured in half space ² AES2 - 1984 compliant ³ Calculated

4 Specifications and Dimensions

4.3.3 Incubus Sub dimensions

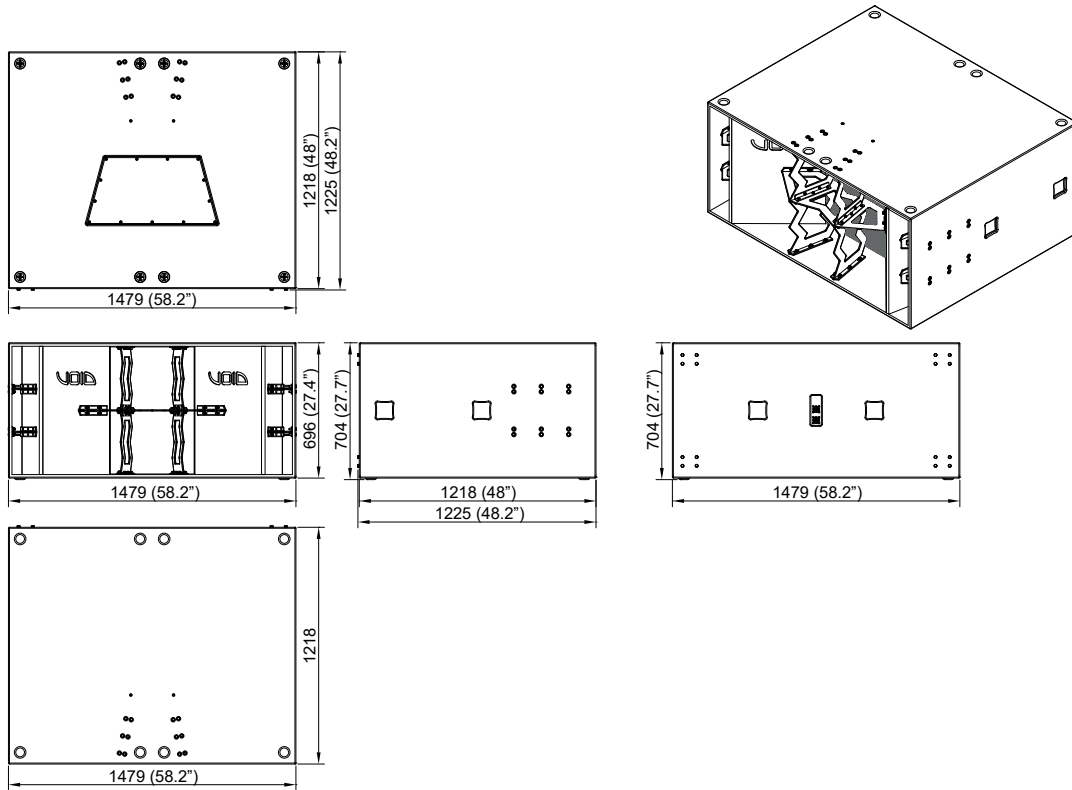

Figure 4.4: Dimensions

4.3.4 Incubus Sub impedance graph

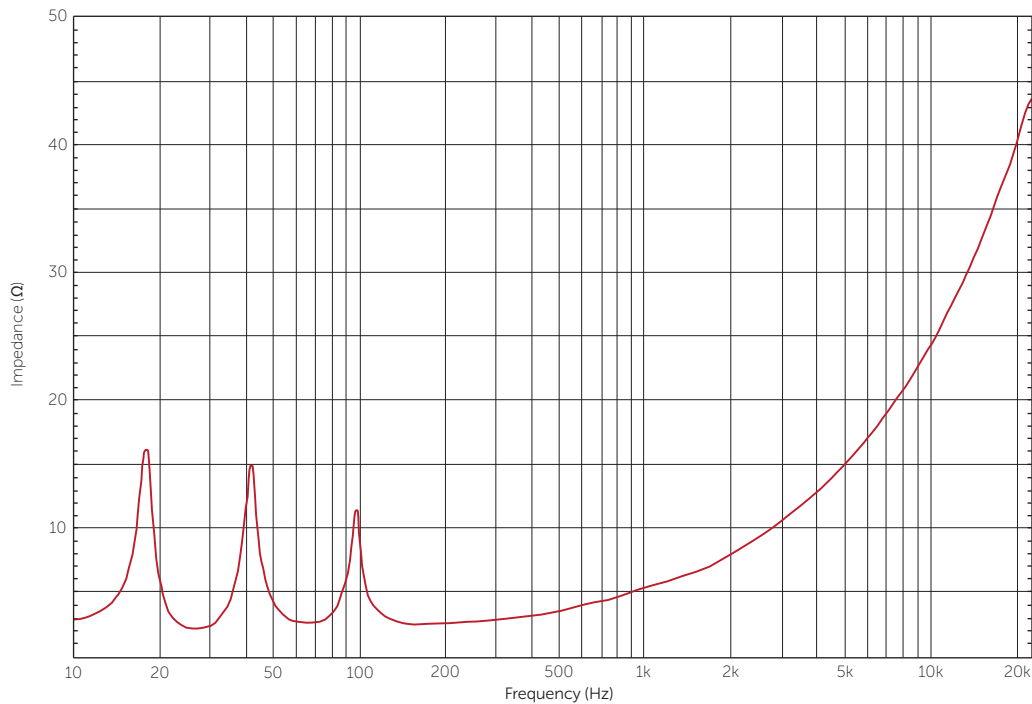

Figure 4.5: Impedance graph

5 Cable and Wiring

5.1 Electrical safety



To avoid electrical hazards please note the following:

- Do not access the inside of any electrical equipment. Refer servicing to Void-approved service agents

5.2 Cable considerations for fixed installations

We recommend specifying installation-grade Low Smoke Zero Halogen (LSZH) cables for permanent installations. The cables should use Oxygen Free Copper (OFC) of grade C11000 or above. Cables for permanent installations should be compliant with the following standards:

- IEC 60332.1 Fire retardancy of a single cable
- IEC 60332.3C Fire retardancy of bunched cables
- IEC 60754.1 Amount of Halogen Gas Emissions
- IEC 60754.2 Degree of acidity of released gases
- IEC 61034.2 Measurement of smoke density

We suggest using the following maximum copper cable lengths to keep level losses below 0.6 dB.

Metric mm ²	Imperial AWG	8 Ω load	4 Ω load	2 Ω load
2.50 mm ²	13 AWG	36 m	18 m	9 m
4.00 mm ²	11 AWG	60 m	30 m	15 m

5.3 Typical amplifier rack array

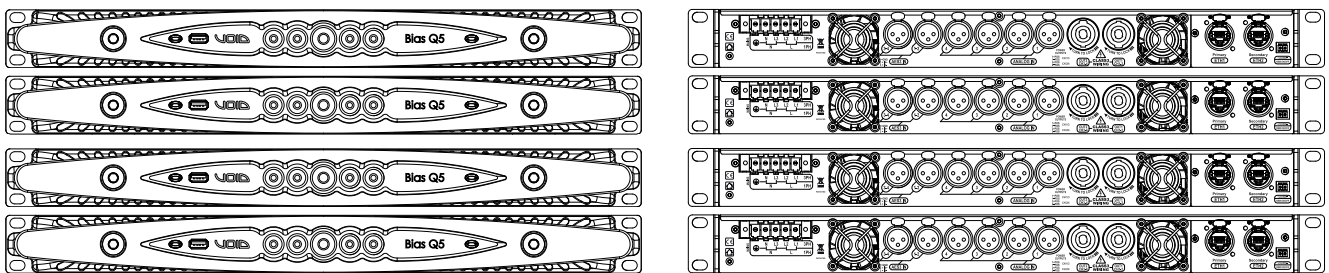

Figure 5.1: Typical amplifier rack layout for Q5

5 Cable and Wiring

5.4 Air Array layout

For clarity throughout this guide the speakON™ connections on the rear of the Air Array will be referred to speakON™ A for the left and speakON™ B for the right as shown in figure 6.1.

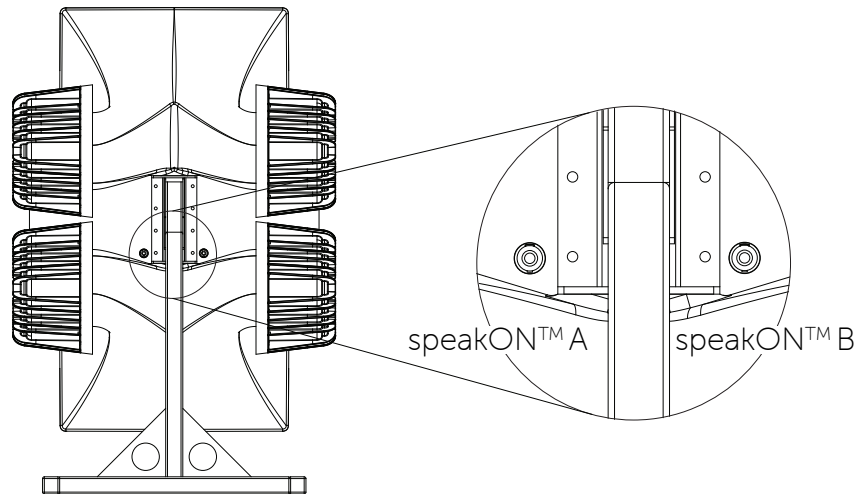

Figure 5.2: speakON™ layout

A further aid given will be a diagrammatic representation of which drivers would be engaged within the loudspeaker for each section. So, for example, figure 6.3 below shows the section for the low frequency drivers.

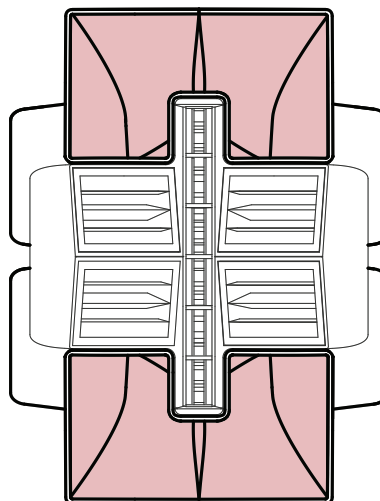

Figure 5.3: LF drivers

5 Cable and Wiring

5.5 Air Array wiring diagram

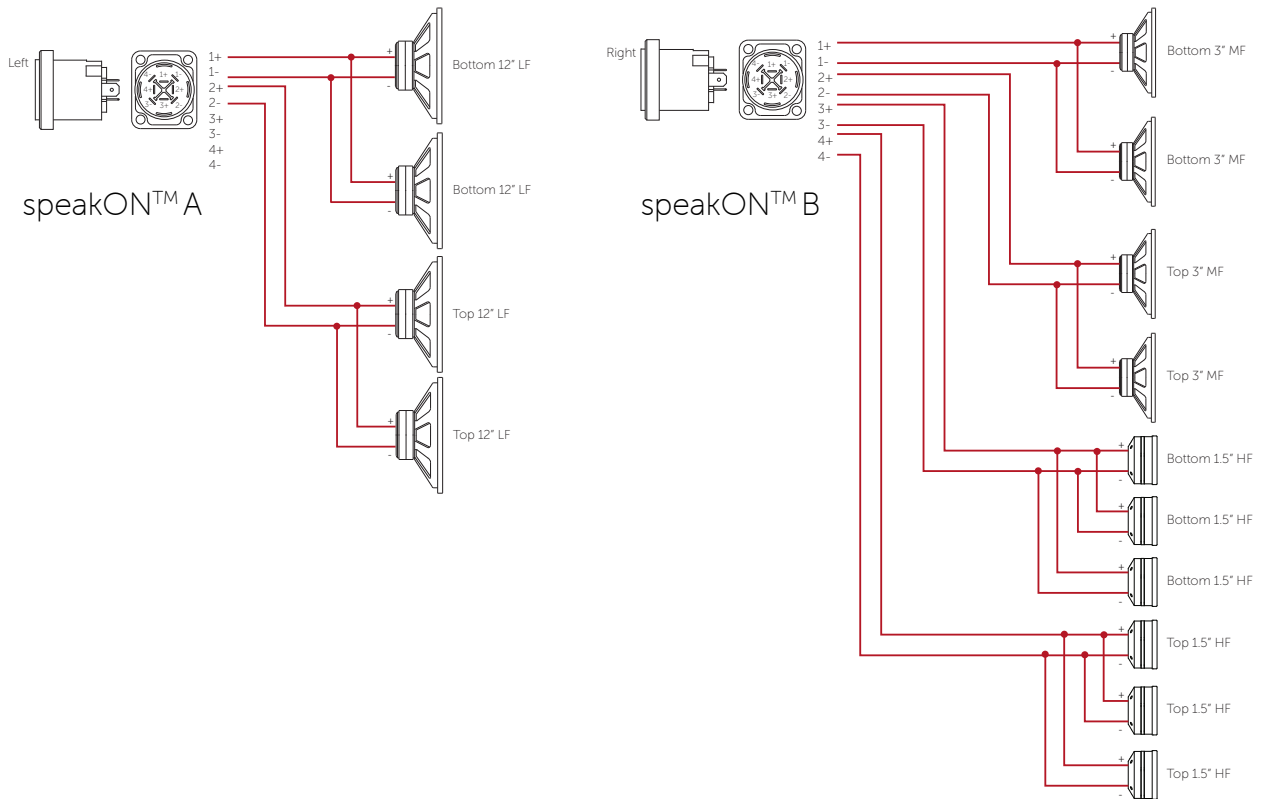

Figure 5.4: Air Array wiring diagram

speakON™ A NL8			
Pins	Driver	Power handling	Impedance
+/-1	Bottom 2 x 12"	1800 W AES	4 Ω
+/-2	Top 2 x 12"	1800 W AES	4 Ω

speakON™ B NL8			
Pins	Driver	Power handling	Impedance
+/-1	Bottom 2 x 3"	400 W AES	4 Ω
+/-2	Top 2 x 3"	400 W AES	4 Ω
+/-3	Bottom 3 x 1"	160 W AES	5.3 Ω
+/-4	Top 3 x 1"	160 W AES	5.3 Ω

5 Cable and Wiring

5.6 Air Array LF Bias Q5 speakON™ A wiring

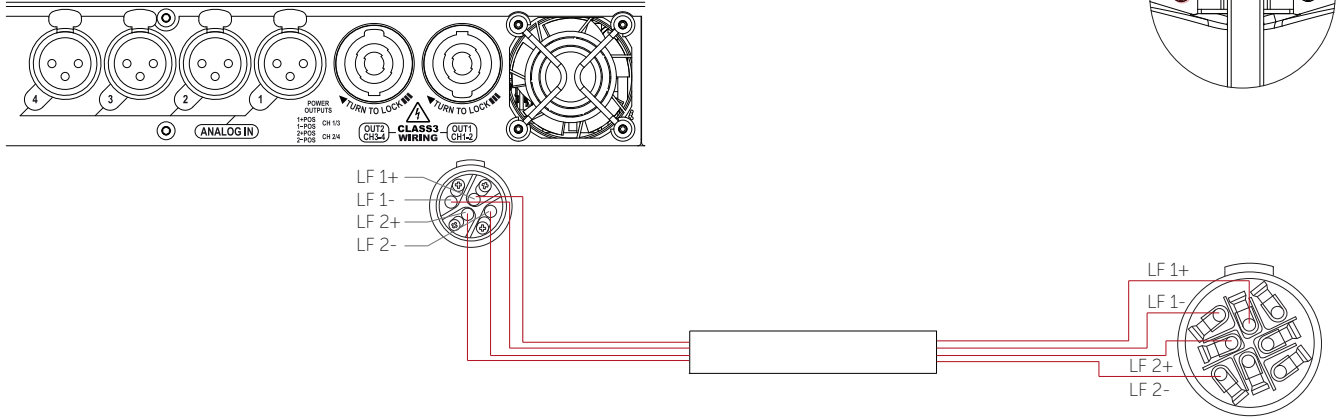
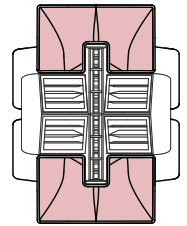

Figure 5.5: Bias V3 left speakON™ A connection
(NOTE: pins +/-3 and +/-4 are not connected)

Bias Q5 for LF (speakON™ A connection)		
Channel	Channel 1	Channel 2
Output	Bottom 2 x 12" LF	Top 2 x 12" LF
speakON™ NL8 pins	+/-1	+/-2



5 Cable and Wiring

5.7 Air Array MHF Bias Q5 speakON™ B wiring

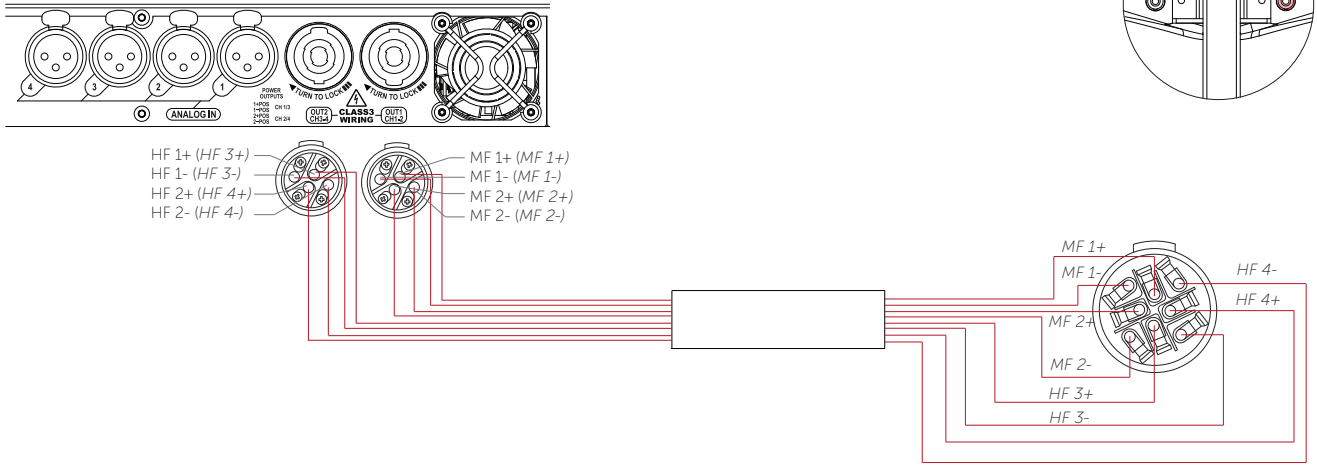
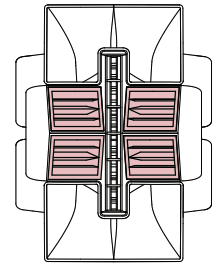
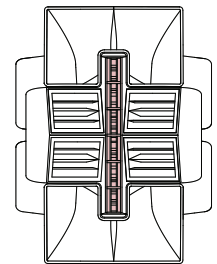

Figure 5.6: Bias Q5 (right speakON™ connection)

Bias Q5 for MF (speakON™ B connection)		
Output 1	Channel 1	Channel 2
Output	Bottom 2 x 3" MF	Top 2 x 3" MF
speakON™ NL8 pins	+/-1	+/-2



Bias Q5 for HF (speakON™ B connection)		
Output 2	Channel 3	Channel 4
Output	Bottom 3 x 1" HF	Top 3 x 1" HF
speakON™ NL8 pins	+/-3	+/-4



5 Cable and Wiring

5.8 Hyperfold wiring diagram

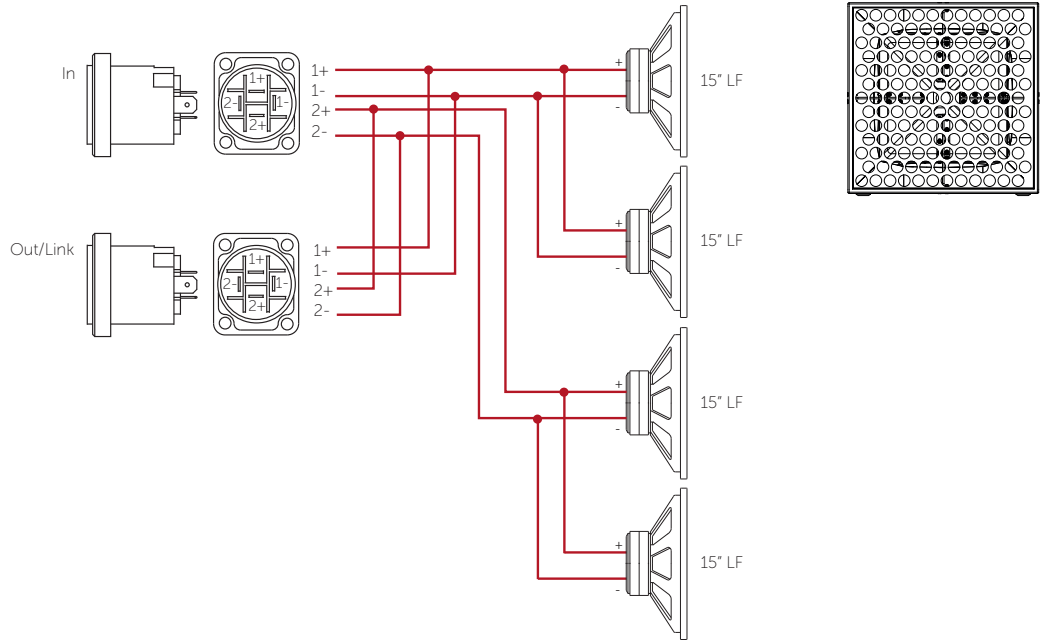

Figure 5.7: Wiring diagram

	speakON™ pins +/-1	speakON™ pins +/-2
In	LF (2 x 15")	LF (2 x 15")
Out	LF link	LF link

5.9 Hyperfold Bias Q5 speakON™ wiring

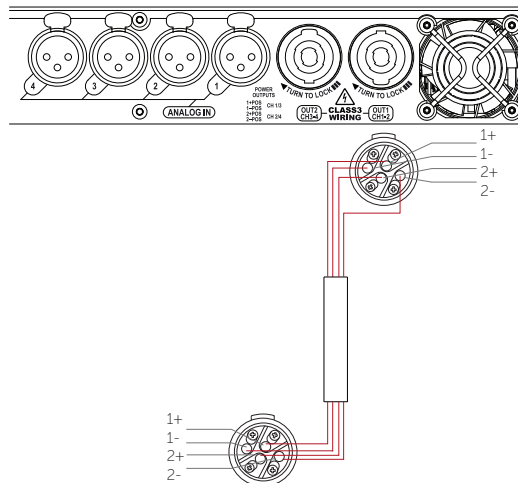

Figure 5.8: Bias Q5

Bias Q5	Channel 1	Channel 2
Output	LF (2 x 15")	LF (2 x 15")
Max parallel units	2 (2 Ω load to amplifier)	2 (2 Ω load to amplifier)

5 Cable and Wiring

5.10 Incubus Sub wiring diagram

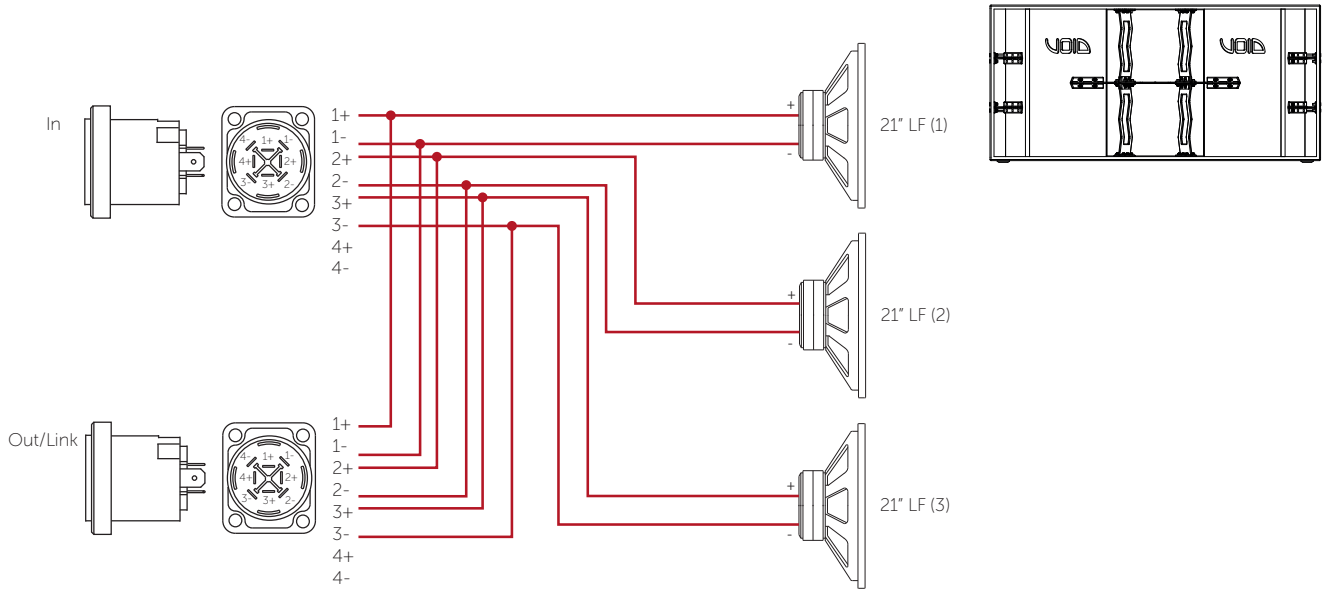

Figure 5.9: Wiring diagram

speakON™ pins	+/-1	+/-2	+/-3	+/-4
In	21" LF (1)	21" LF (2)	21" LF (3)	n/c
Out	LF link	LF link	LF link	n/c

5 Cable and Wiring

5.11 Incubus Sub Bias Q5 speakON™ wiring

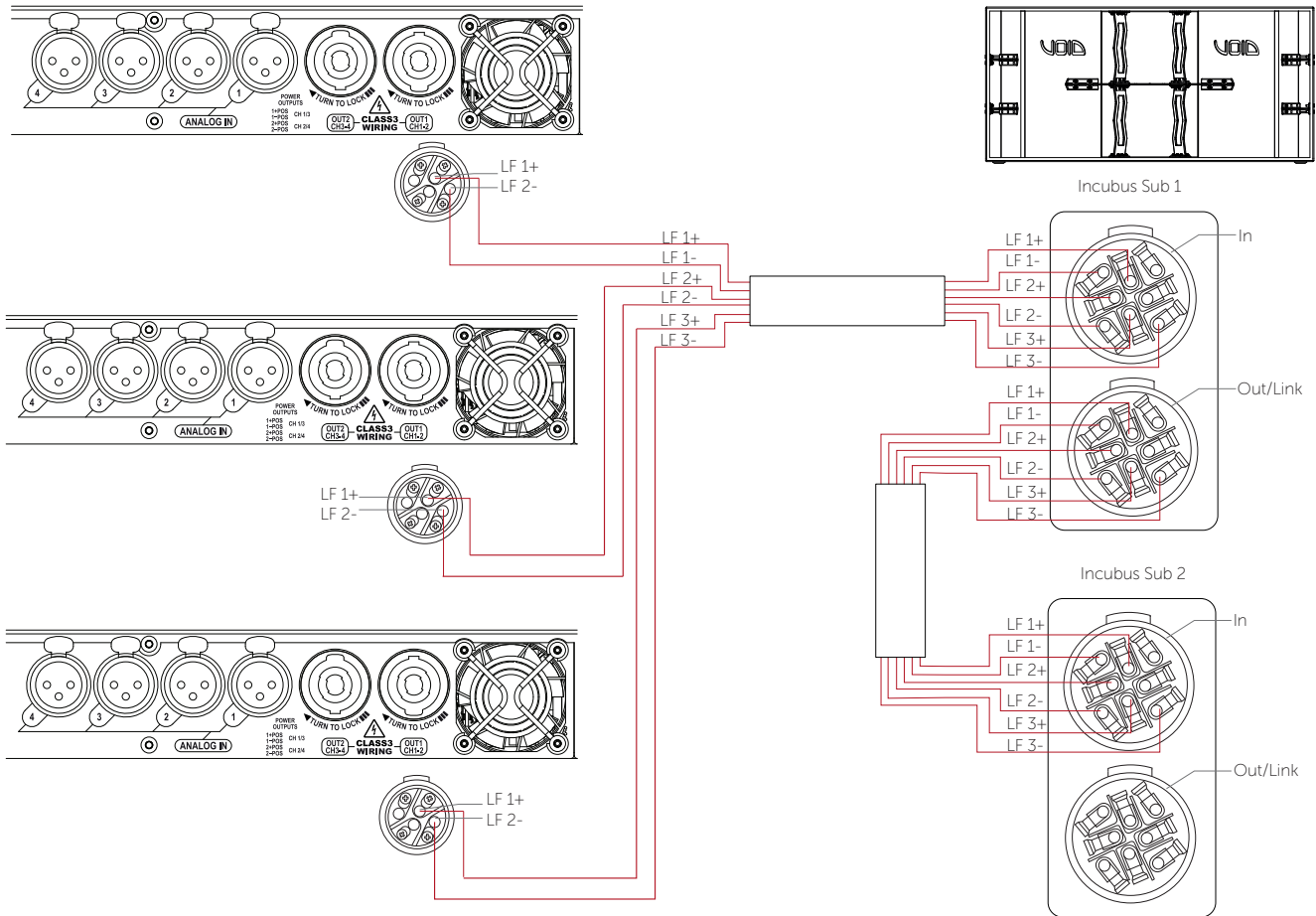

Figure 5.10: Bias Q5

Amplifier	Bias Q5 1	Bias Q5 3	Bias Q5 3
Output	Output 1	Output 1	Output 1
speakON™ NL4 pins	1+/2-	1+/2-	1+/2-
Drivers	21" LF (1)	21" LF (2)	21" LF (3)
speakON™ NL8 pins	1+/1-	2+/2-	3+/3-

6 Mounting

Tools required

- 19 mm ratchet spanner/wrench
- 6 mm Allen key

6.1 Installation safety



To avoid mechanical hazards, please note the following:

- Safety regulations vary in different regions. Full compliance with those regulations must be your priority
- Installations must only be undertaken by fully qualified and experienced engineers/technicians who understand local regulations
- This may include consulting a structural engineer before installation of wall brackets
- Remember that all personnel have a duty of care to themselves, to their assistants, to the venue staff and to the public
- Before lifting any part of the system above head height, check the whole rig for loose tools or other items that may fall and cause injury
- Do not use a telephone (even if hands-free) whilst installing. Always concentrate fully on the installation operation
- Do not install equipment that is worn, damaged, corroded, mishandled or overstressed in any way
- Use only Void-approved mounting equipment and accessories
- Secondary safeties should be provided in all instances where cabinets are flying or fixing overhead and should conform to local regulations

6.2 Ground Stack Bracket

Step 1:

Remove the backing plate from the Air Array bracket by removing both M12 bolts from the bracket assembly.

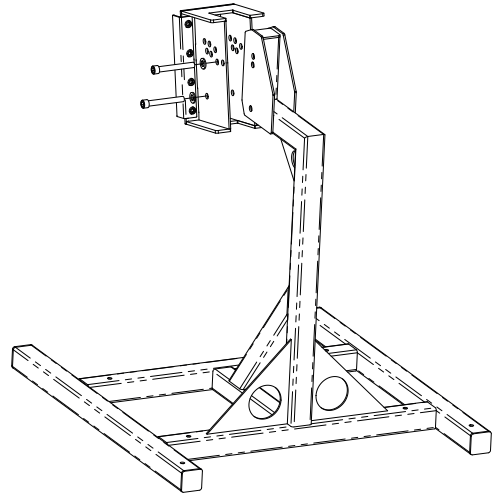

Figure 6.1: Backing plate removal

Step 2:

Remove all eight M8 bolts from the rear of the Air Array loudspeaker.

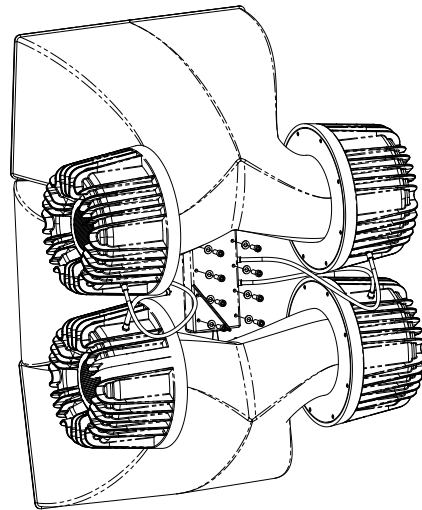

Figure 6.2: M8 bolt removal

Step 3:

Attached the backing plate to the Air Array ensuring that all eight M8 bolts are securely fastened.

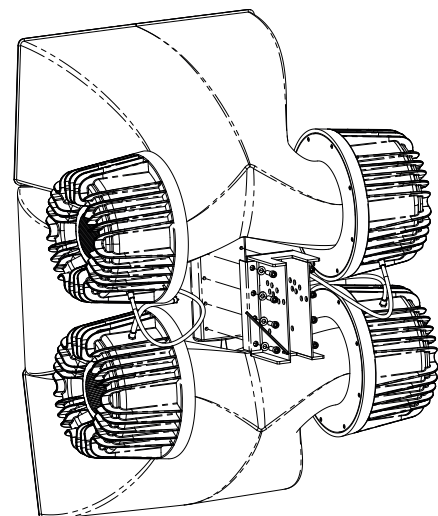

Figure 6.3: Backing plate attachment

6.2 Ground Stack Bracket

Step 4:

Carefully lower the Air Array loudspeaker into position onto the bracket assembly and attach the M12 bolt through the bracket assembly.

Note: Air Array loudspeakers are heavy and require a minimum of two people to lift. At this stage of the mounting procedure it becomes necessary to have three people, two to lift the Air Array loudspeaker and one to attach the bracket.

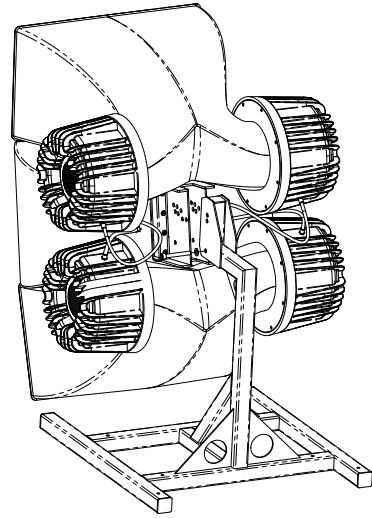

Figure 8.4: Air Array positioning

Step 5:

Adjust the vertical angle of the Air Array to the required position.

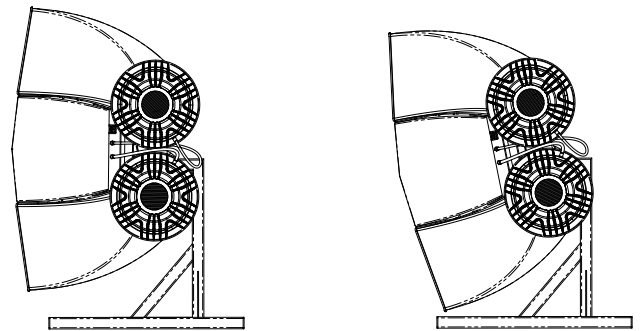

Figure 8.5: Vertical angle positioning

Step 6:

Fit the M12 through the appropriate slot.

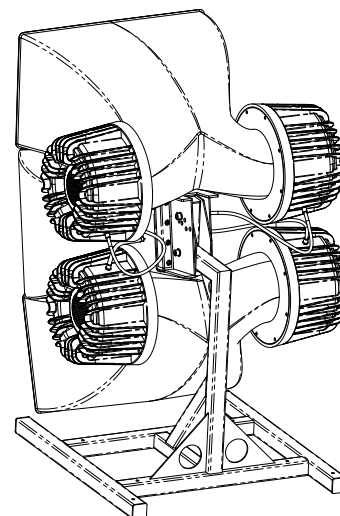

Figure 8.6: M12 bolt fixing

7 Adjustments

To avoid damage when making adjustments please note the following:



- Removing the grille can cause debris to collect within the enclosure, take care to remove anything that may have collected internally
- Do not use impact tools.

7.1 Wheel removal

Step 1:
Remove all four M6 bolts with a 13 mm spanner/wrench.

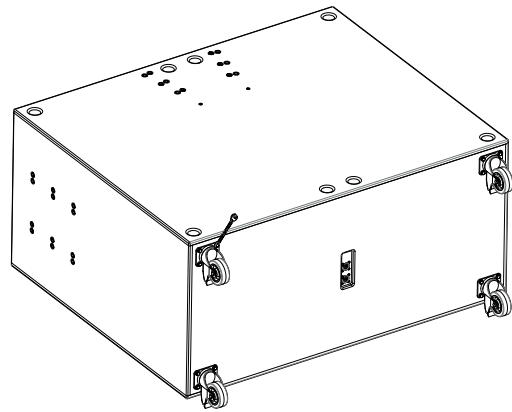

Figure 7.1: Bolt removal

Step 2:
Remove/add the wheels and keep in a safe place. Repeat the process for the other three wheels.

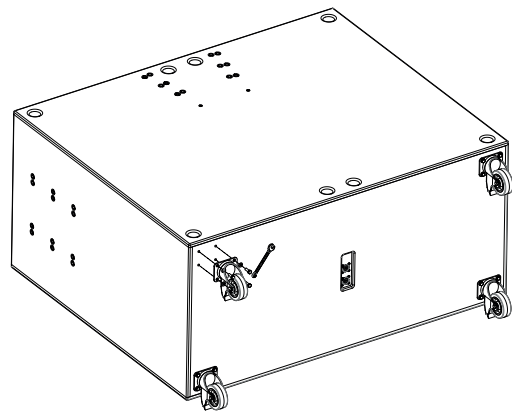

Figure 7.2: Wheel removal

Step 3:
Replace the M8 bolts by hand until finger tight before using hand tools.



Note: Replacing bolts is of particular importance as without them there can be air leakage and detuning.

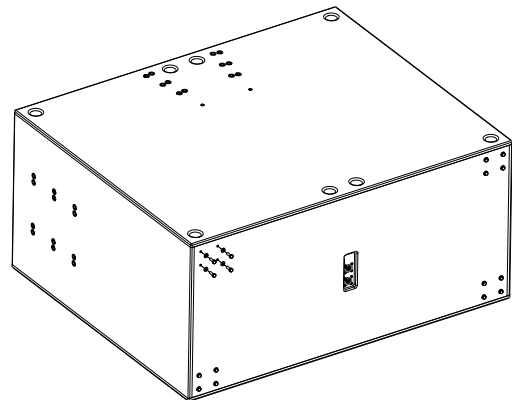

Figure 7.3: Bolt tightening

7 Adjustments

7.2 Hyperfold grille removal

Step 1:

Undo all eight M6 tab bolts using a 4 mm Allen key, take care NOT to remove the tab bolts as they may become lost within the enclosure.

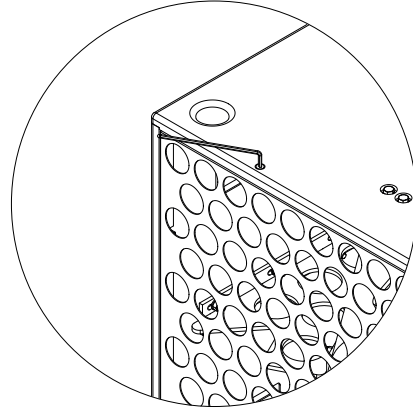

Figure 7.4: Bolt removal

Step 2:

Remove grille.

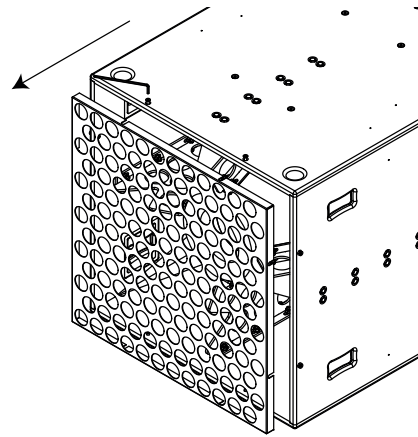

Figure 7.5: Grille removal

Step 3:

Replace the M6 bolts by hand until finger tight before using hand tools.

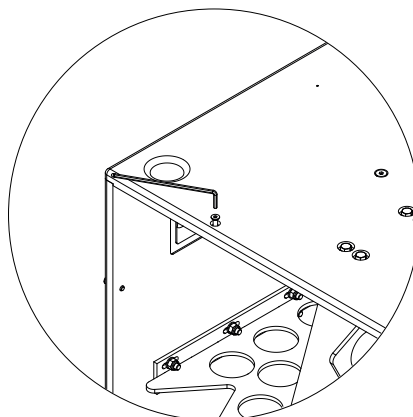

Figure 7.6: Bolt replacement

8 Service

Void Incubus System loudspeakers should only be serviced by a fully-trained technician.



No user serviceable parts inside. Refer servicing to your dealer.

8.1 Return authorisation

Before returning your faulty product for repair, please remember to get an R.A.N. (Return Authorisation Number) from the Void dealer who supplied the system to you. Your dealer will handle the necessary paperwork and repair. Failure to go through this return authorisation procedure could delay the repair of your product.

Note that your dealer will need to see a copy of your sales receipt as proof of purchase so please have this to hand when applying for return authorisation.

8.2 Shipping and packing considerations

- When sending a Void Incubus System loudspeaker to an authorised service centre, please write a detailed description of the fault and list any other equipment used in conjunction with the faulty product.
- Accessories will not be required. Do not send the instruction manual, cables or any other hardware unless your dealer asks you to.
- Pack your unit in the original factory packaging if possible. Include a note of the fault description with the product. Do not send it separately.
- Ensure safe transportation of your unit to the authorised service centre.

9 Appendix

Air Array architectural specifications

The loudspeaker shall be an active three-way system with independent dedicated amplification consisting of four high power 12" (304.8 mm) horn loaded low frequency (LF) transducers, a mid frequency section consisting four 3" (76.2 mm) mid frequency (MF) compression drivers with attached waveguides and six 1" (25.4 mm) high frequency (HF) compression driver mounted on a waveguide to allow constant directivity.

Two hyperbolic horns fed from a split manifold and driven by the four LF transducers shall provide the low frequency section. Each LF transducer shall be enclosed in an independent moulded fibreglass enclosure featuring a heatsink cooling system to reduce power compression levels. Mid frequency transducers are in a sealed enclosure mounted in a V baffle configuration for a more coherent radiation pattern over frequency range. HF transducers shall be arranged in a line source configuration positioned on a physical arc, providing a virtual common feed point, resulting in an improved directivity pattern control and higher SPL over the high frequency range. Line source behavioural conditions are met by all sections hence allowing frequency and power shading within a single enclosure.

The LF transducers shall be constructed on a cast aluminium frame, with a treated paper cone, 101.6 mm (4") voice coil, wound with copper wires on a high quality voice coil former and neodymium magnets, for high power handling and long term-reliability. Each 3" MF transducer shall have a 6" diaphragm reproducing frequencies down to 500 Hz, and shall be mounted on a high standard waveguide with path length compensation for a better directivity pattern control over the frequency spectrum. The HF transducers shall project sound through a high precision planar waveguide to achieve pattern control and low distortion.

Performance specifications for a typical production unit shall be as follows: the usable on-axis bandwidth shall be 90 Hz to 26 kHz (± 3 dB), with an average 45° directivity pattern on the vertical axis and 90° on the horizontal one (-6 dB down from on-axis level) from 1 kHz to 12 kHz; maximum SPL of 152 dB peak measured at 1 m using IEC268-5 pink noise. Power handling shall be 3600 W AES for the LF section at a rated impedance of $2 \times 4 \Omega$, 800 W AES for the MF section at a rated impedance of $2 \times 4 \Omega$ and 320 W AES for the HF section at a rated impedance $2 \times 5.3 \Omega$. The system shall be powered by its own dedicated power amplification modules with DSP management, from which crossover points will also be set. The wiring connection shall be via two Neutrik speakON™ NL8. The left NL8 shall be used to power the LF section and the right one shall power the MHF section.

The enclosure shall be of a fibreglass composite with a smooth cellulose finish of any RAL colour. The system shall be stack mounted with a dedicated stand or can also be flown with a load tested suspension system. The external dimensions of the enclosure shall be (W) 944 mm x (H) 1240 mm x (D) 813 mm (37.2" x 48.8" x 32"). Weight shall be 144.8 kg (319.2 lbs) including stand.

The loudspeaker shall be the Void Acoustics Air Array.

9 Appendix

Hyperfold architectural specifications

The loudspeaker shall be an active manifold horn loaded sub system consisting of four high power 15" (381 mm), long excursion, low frequency (LF) transducers mounted in a birch plywood enclosure.

Each low frequency transducer shall be constructed on a cast aluminium frame, with a treated paper cone, 101.6 mm (4") voice coil, wound with copper wires on a high quality voice coil former for high power handling and long-term reliability.

Performance specifications for a typical production unit shall be as follows: the usable bandwidth shall be 60 Hz to 190 Hz (± 3 dB); maximum SPL of 152 dB peak (146 dB continuous) measured at 1 m using IEC268-5 pink noise. Power handling shall be 4000 W AES at a rated impedance of 2 Ω (2 x 4 Ω) with pressure sensitivity at 109.5 dB measured at 1W/1m. The system shall be powered by its own dedicated power amplification module with DSP management. The wiring connection shall be via two Neutrik speakON™ NL4 (one for input and one for loop-out to another speaker), allow for pre-wiring of the connector before installation.

The enclosure shall be constructed from 18 mm multi-laminate birch plywood coated with textured polyurea with a smooth cellulose finish. It shall have a lightweight aluminium bracing and external dimensions of (H) 748 mm x (W) 738 mm x (D) 1218 mm (29.4" x 29.1" x 47.9"). Weight shall be 150 kg (330.7 lbs).

The loudspeaker shall be the Void Acoustics Hyperfold.

9 Appendix

Incubus Sub architectural specifications

The loudspeaker shall be an active bandpass-horn hybrid system consisting of three high power 21" (533.4 mm), long excursion, low frequency (LF) transducers mounted in a rectangular enclosure.

Each low frequency transducer shall be constructed on a cast aluminium frame, with a treated paper cone, 152.4 mm (6") voice coil, wound with copper wires on a high quality voice coil former for high power handling and long-term reliability.

Performance specifications for a typical production unit shall be as follows: the usable bandwidth of 29 Hz to 95 Hz (± 3 dB), with a maximum SPL of 148 dB peak (142 dB continuous) measured at 1 m using IEC268-5 pink noise. Power handling shall be 6000 W AES at a rated impedance of $3 \times 8 \Omega$ and a pressure sensitivity of 105 dB measured at 1W/1m. The system shall be powered by its own dedicated power amplification module with DSP management. The wiring connection shall be via two Neutrik speakON™ NL8 (one for input and one for loop-out to another speaker), to allow for pre-wiring of the connector before installation.

The enclosure shall be constructed from a 18 mm multi-laminate birch plywood finished in a textured 'TourCoat' polyurea. It shall have lightweight aluminium bracing and external dimensions of (H) 704 mm x (W) 1479 mm x (D) 1218 mm (27.7" x 58.2" x 48"). Weight shall be 214 kg (471.8 lbs).

The loudspeaker shall be the Void Acoustics Incubus Sub.

NORTH AMERICA

Void Acoustics North America

Call: +1 630 686 6616

Email: hello@voidacoustics.com

HEAD OFFICE

Void Acoustics Research Ltd,
Unit 15, Dawkins Road Industrial Estate,
Poole, Dorset,
BH15 4JY
United Kingdom

Call: +44(0) 1202 666006

Email: hello@voidacoustics.com



Hear. Feel. Connect.

voidacoustics.com